

ORDER NUMBER	TYPE
WS F20 74 1	68 ... 87.5 MHz, with radome, low profile
WS F30 31 1. .	3 dB 137 ... 174 MHz
WS F30 31 1. .	mountings
WS F30 74 15/6	146 ... 174 MHz, GSM, UMTS, WLAN with radome, low profile
WS F30 84 1.	140 ... 174 MHz with radome
WS F40 31 1.	3 dB 220 ... 470 MHz
WS F40 31 1.	mountings
WS F40 61 17 .	380 - 400 MHz
WS F40 68 16	4 dB 370 ... 390 MHz
WS F40 74 14	380 ... 430 MHz with radome, low profile
WS F40 83 1.	4 dB 370 ... 470 MHz with radome
WS F40 84 1.	370 ... 470 MHz with radome
WS F60 31 1. 8	3 dB 860 - 960 MHz
WS F60 31 1. 8	mountings
WS F60 83 18	800 - 970 MHz 3 dB with radome
WS F.R ..	Radiators for base WS F0R 65
WS F0R 65 D	Base for radiators and spring to base

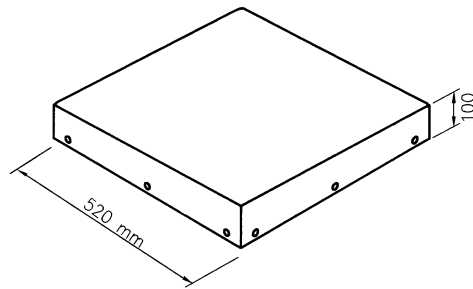

TYPE	WS F20 74 1: (desired frequency)
DESCRIPTION	omnidirectional antenna, very low construction The antenna must be adjusted on the car, either from the roof or from the interior of the vehicle. When placing your order indicate your preference interior or exterior adjustment.
POLARIZATION	vertical
IMPEDANCE	50 Ω
GAIN	0 dB (ref. λ/4 dipole)
VSWR	< 1.5 on Tx frequency
POWER	50 watts
RADIATION PATTERN	omnidirectional
GROUNDING	all metal parts are DC grounded
TERMINATION	BNC female, other termination on request
MOUNTING	with 12 screws on conducting surface of at least 1 m ²
BREAKDOWN VOLTAGE	3000 VDC
MATERIAL	radiating element and base plate: aluminium Cr/Ni -plated copper, bolts of stainless steel, radome of fiberglass
WEIGHT	5.1 kg
WINDAREA	0.05 m ²
WINDLOAD	66 N at 150 km/h 49 N at 130 km/h

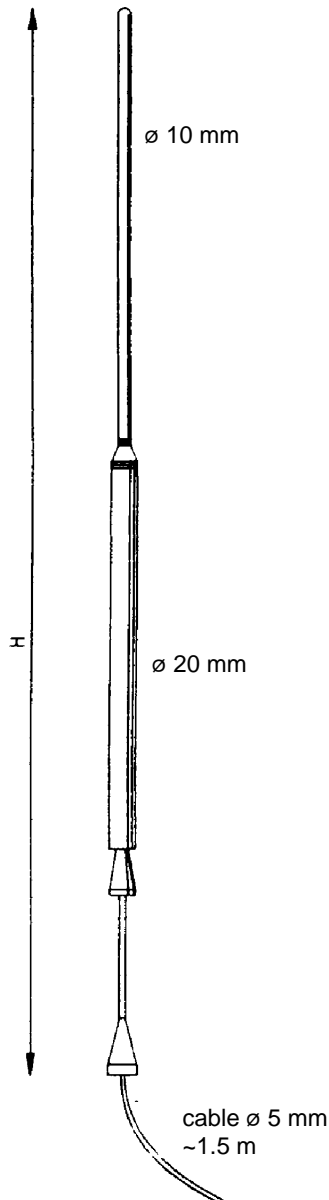

TYPE NO.	WS F30 31 1. 7: 137 ... 149 MHz WS F30 31 1. 8: 146 ... 159 MHz WS F30 31 1. 9: 156 ... 174 MHz tuned on the requested frequency
DESCRIPTION	The antenna is decoupled from the carrier tube and needs no counter weight. The antenna is specially designed for motorcycles and vehicules with plastic roofs.
POLARIZATION	vertical
IMPEDANCE	50 Ω
GAIN	3 dB (ref to a $\lambda/4$ dipole)
VSWR	< 1.3 on tuned frequency
POWER	30 Watt
TERMINATION	1.5 m cable with \varnothing 5mm, without connector the cable must not be shortened (transformer)
GROUNDING	radiator not grounded
MOUNTING	see next page
MATERIAL	anodized aluminium, bolts and spring of stainless steel, rugged plastic base
HEIGHT H	WS F30 31 1. 7: 1.2 m WS F30 31 1. 8: 1.15 m WS F30 31 1. 9: 1.1 m

WS F30 31 12 .
with spring

WS F30 31 13 .
no longer available

WS F30 31 14 .
with spring and stright
mounting flange

WS F30 31 15 .
with mounting clamp

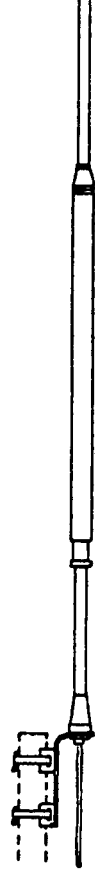
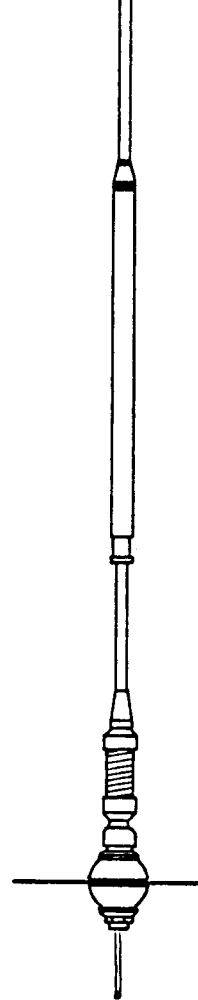
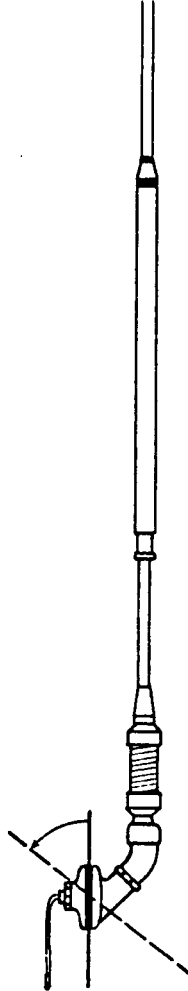

MOUNTING:
on horizontal plane
hole \varnothing 16 mm

MOUNTING:
on planes with no slope
hole \varnothing 24 mm

MOUNTING:
on masts, ralings etc.
with metallic assembly
line

WEIGHT: 750 g

WEIGHT: 1100 g

WEIGHT: 450 g



320 mm

85 mm

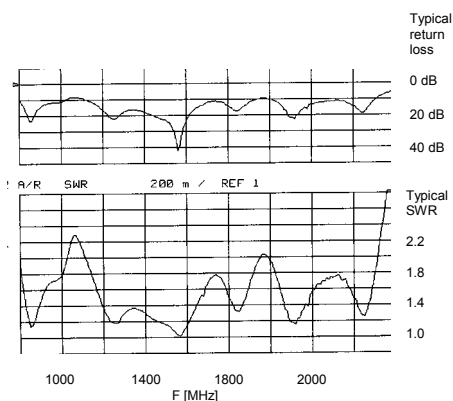
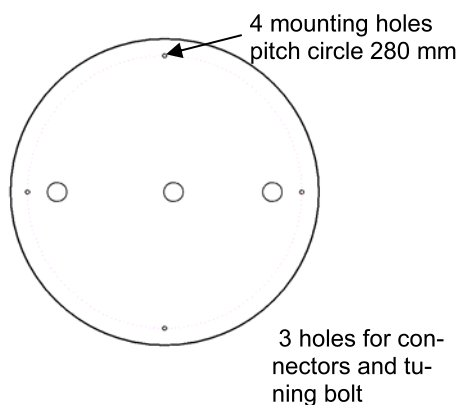

BAND 146 ... 174 MHz	tuned on desired frequency
DESCRIPTION	omnidirectional antenna, very low profile construction, radome protected The antenna is tunable on conducting or nonconducting surfaces.
POLARIZATION	vertical
IMPEDANCE	50 Ω
GAIN	-2 dB (ref. λ/4 antenna)
VSWR	< 1.5 on tuned frequency bandwidth 1 MHz (VSWR 2)
POWER	150 watts
RADIATION PATTERN	omnidirectional
GROUNDING	all metal parts are DC grounded
TERMINATION	BNC female, other termination on request
BAND 860-2500 MHz	GSM 900, 1800, 1900, UMTS, WLAN
DESCRIPTION	built in the radome of the 2 m antenna
POLARIZATION	vertical
IMPEDANCE	50 Ω
GAIN	0 dB (ref. λ/2 dipole)
POWER	25 W
RADIATION PATTERN	almost round on all bands
TERMINATION	TNC female
MOUNTING	with 4 bolts Ø 5 mm (not included) 3 holes for connectors and tuning bolt, drill 20 mm
MATERIAL	aluminium, bolts of stainless steel, radome of weather-resistant ASA
WEIGHT	1 kg
WINDAREA	0.02 m ²
WINDLOAD	26 N at 150 km/h 20 N at 130 km/h

WIPIC reserves the right to amend specifications in the light of continuing development.
KW 9-04

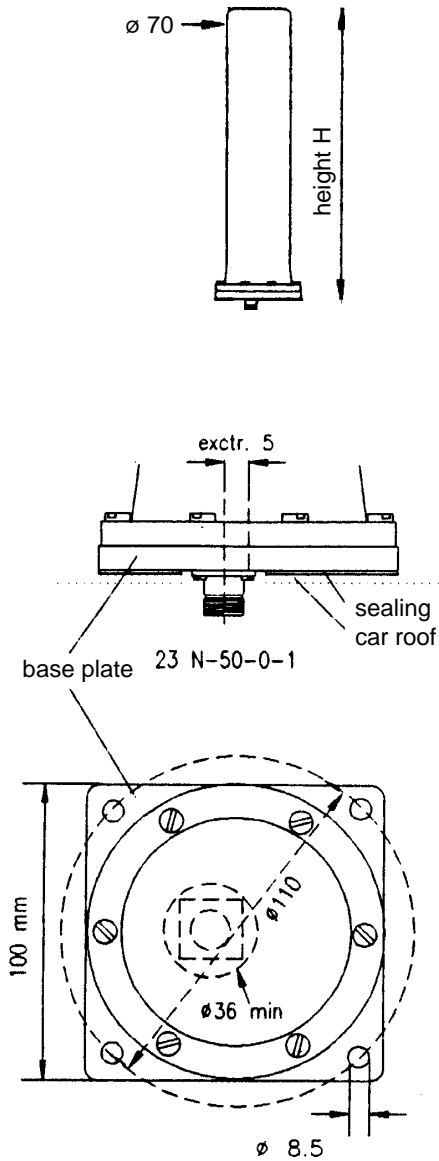

TYPE NO.	type	frequency	height
	WS F30 84 16:	142 - 149 MHz	470 mm
	WS F30 84 17:	147 - 156 MHz	455 mm
	WS F30 84 18:	155 - 166 MHz	430 mm
	WS F30 84 19:	164 - 174 MHz	410 mm

Tested for rail use according to EN 50388:05

POLARIZATION	vertikal
IMPEDANCE	50 Ω
GAIN	0 dB (ref. $\lambda/4$ Dipol)
VSWR	< 1.4
POWER	300 Watt
TERMINATION	N chassis female 23 N-50-0-1
GROUNDING	all metal parts are DC grounded
MOUNTING	on conductive surface with 1m ² at least with 4 screws M8
MATERIAL	aluminium, bolts of stainless steel, radome of uv-stabilized polyethylene
WEIGHT	0.9 kg
WIND AREA	0.03 m ²
WIND LOAD	28 N at 150 km/h 38 N at 130 km/h 68 N at 200 km/h

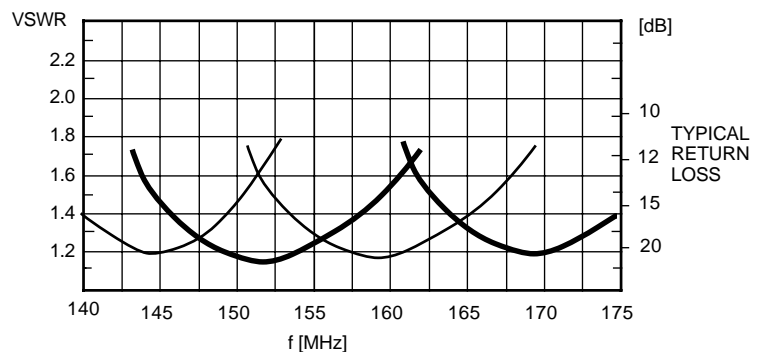

ANTENNA FOR MOTO CYCLES WS F40 31 1. (freq.) 220 ... 470 MHz

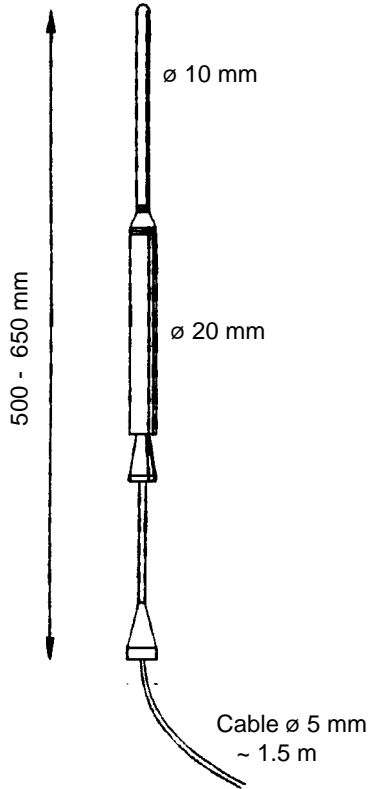

TYPE NO.	WS F40 31 1. : (desired frequency) other frequency on request
DESCRIPTION	The antenna is decoupled from the carrier tube and needs no counter weight. The antenna is specially designed for motorcycles and vehicules with plastic roofs.
POLARIZATION	vertical
IMPEDANCE	50 Ω
GAIN	3 dB (ref. to a $\lambda/4$ dipole)
VSWR	< 1.3 on tuned frequency
POWER	30 Watt
TERMINATION	1.5 m cable with \varnothing 5mm, without connector the cable must not be shortened (transformer)
GROUNDING	radiator not grounded
MOUNTING	see next page
MATERIAL	aluminium, bolts and spring of stainless steel, rugged plastic base

WIPIC reserves the right to amend specifications in the light of continuing development.

KW 1-08

LETRONA AG

Schulstrasse 22, CH-9504 Friltschen
Tel.: +41 071 654 64 64, Fax : +41 071 654 64 65
E-Mail: info@letrona.ch

Management-System
Zertifiziert ISO 9001: 2000
Reg. - Nr. 11996-03

WS F40 31 12

with spring

WS F40 31 13

no longer available

WS F40 31 14

with spring and stright
mounting flange

WS F40 31 15

with monting clamp

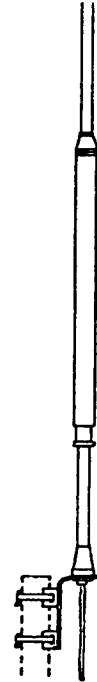
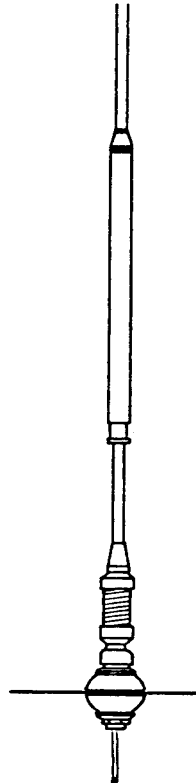
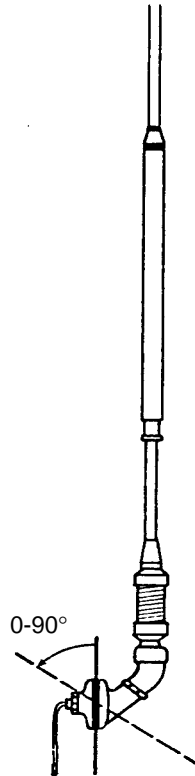

MOUNTING:
on horizontal plane
hole \varnothing 16 mm

WEIGHT: 650 g

MOUNTING:
on planes with no slope
hole \varnothing 24 mm

WEIGHT: 1100 g

MOUNTING:
on masts, railings etc.
with metallic assembly
line

WEIGHT: 350 g

KW 1-08

LETRONA AG

Schulstrasse 22, CH-9504 Frittschen
Tel.: +41 071 654 64 64, Fax : +41 071 654 64 65
E-Mail: info@letrona.ch

SQS

Management-System
Zertifiziert ISO 9001: 2000
Reg. - Nr. 11996-03

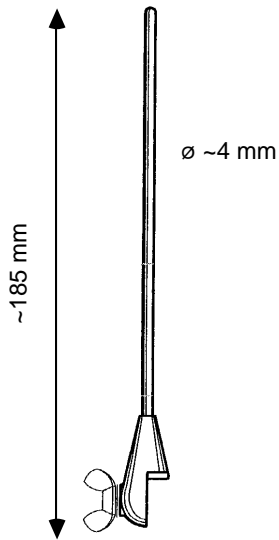

TYPE NO.	WS F40 61 17 radiator: 380 - 400 MHz further frequencies on request
DESCRIPTION	bright
POLARISATION	vertical
IMPEDANCE	50 Ω
GAIN	0 dB (ref. to a $\lambda/4$ dipole)
SWR	< 2 (tuned to a commercial base)
MAX. POWER	30 watts
MOUNTING	swivel-joint fitting
MATERIAL	whip and screw: stainless steel mount: brass nickel-plated wing: robust plastic
LENGTH	~ 185 mm
WEIGHT	~ 65 g

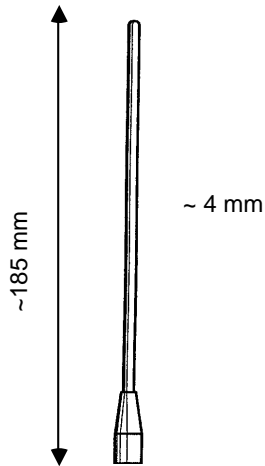

TYPE NO.	WS F40 61 17 1 radiator: 380 - 400 MHz further frequencies on request
DESCRIPTION	surface black or bright
POLARISATION	vertical
IMPEDANCE	50 Ω
GAIN	0 dB (ref. to a $\lambda/4$ dipole)
SWR	< 2 (tuned to a commercial base)
MAX. POWER	30 watts
MOUNTING	M6 thread or screw
MATERIAL	whip: stainless steel mount: brass
LENGTH	~ 185 mm
WEIGHT	~ 45 g

**RADIATER TO MOBILE ANTENNA
WS F40 68 16
380 - 400 MHz**

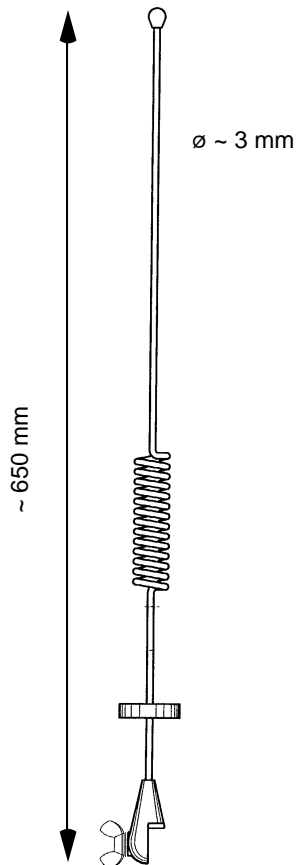

TYPE NO.	WS F40 68 16 radiator: 380 - 400 MHz further frequencies on request
DESCRIPTION	bright
POLARISATION	vertical
IMPEDANCE	50 Ω
GAIN	4 dB (ref. to a $\lambda/4$ dipole)
SWR	< 2 (tuned to a commercial base)
MAX. POWER	30 watts
MOUNTING	swivel-joint fitting
MATERIAL	whip and screw: stainless steel mount: brass nickel-plated wing: robust plastic
LENGTH	~ 650 mm
WEIGHT	~ 125 g

KW 1-08

LETRONA AG

Schulstrasse 22, CH-9504 Frittschen
Tel.: +41 071 654 64 64, Fax : +41 071 654 64 65
E-Mail: info@letrona.ch



upper \varnothing 120

lower \varnothing 175 mm

height 90 mm

TYPE NO.	WS F40 74 14: 380 - 430 MHz further frequencies on request
DESCRIPTION	omnidirectional antenna, low profile
POLARIZATION	vertical
IMPEDANCE	50 Ω
GAIN	0 dB (ref. $\lambda/4$ dipole)
VSWR	≤ 1.7
POWER	150 Watt
TERMINATION	20 cm cable RG 58 with FME male other termination on request
GROUNDING	al metal parts are DC grounded
MOUNTING	one-hole mounting drilling diameter 24 mm on a conductive surface with 1m ² at least
MATERIAL	aluminium, bolts of stainless steel radome of UV-stabilized polyethylene
WEIGHT	0.8 kg
WIND AREA	0.011 m ²
WIND LOAD	14 N at 150 km/h 10 N at 130 km/h 25 N at 200 km/h

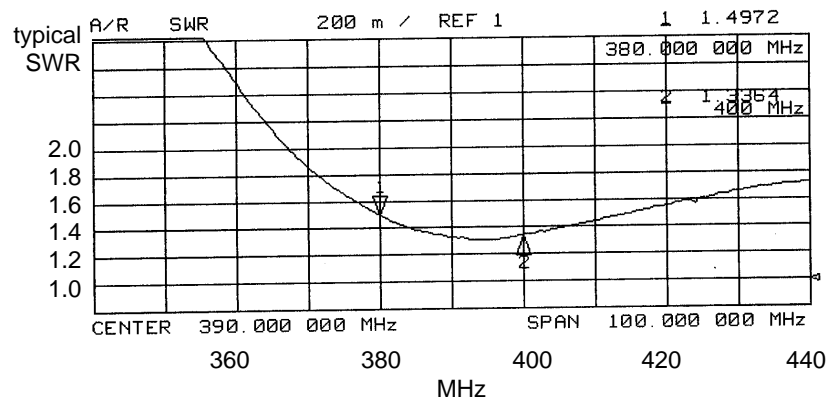

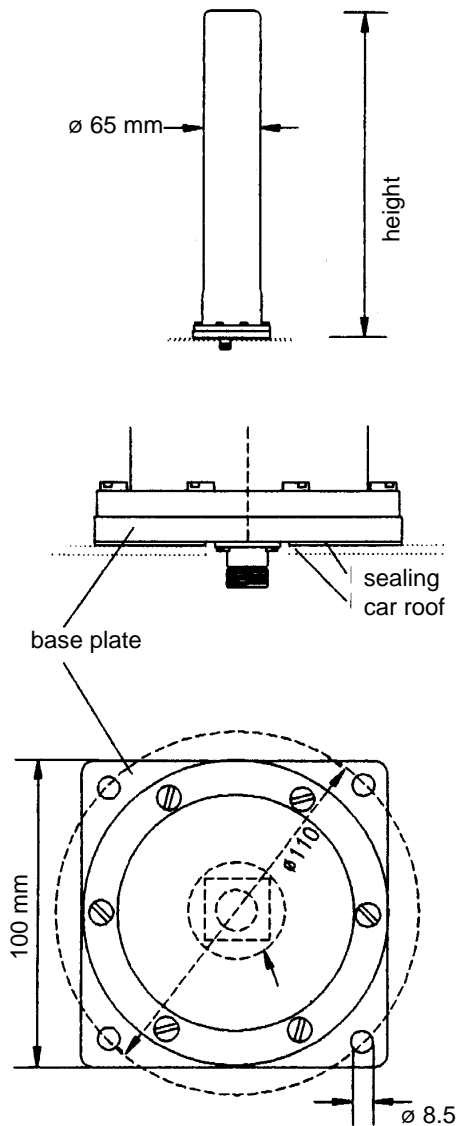

TYPE NO.	WS F40 83 15:	370 - 400 MHz
	WS F40 83 16:	390 - 410 MHz
	WS F40 83 17:	410 - 430 MHz
	WS F40 83 18:	430 - 450 MHz
	WS F40 83 19:	450 - 470 MHz
	Tested for rail use according to EN 50388:05	
POLARIZATION	vertikal	
IMPEDANCE	50 Ω	
GAIN	4 dB (ref. a λ/4 dipole)	
VSWR	< 1.5	
POWER	150 Watt	
TERMINATION	N chassis female 23 N-50-0-1 other termination on request	
GROUNDING	radiator not DC grounded	
MOUNTING	on conductive surface with 1m ² at least	
MATERIAL	aluminium, steel, bolts of stainless steel, radome of UV-stabilized polyethylene	
HEIGHT	WS F ... 5-7	620 mm
	WS F ... 8-9	655 mm
WEIGHT	1.0 kg	
WIND AREA	0.04 m ²	
WIND LOAD	51 N at 150 km/h	
	38 N at 130 km/h	
	91 N at 200 km/h	

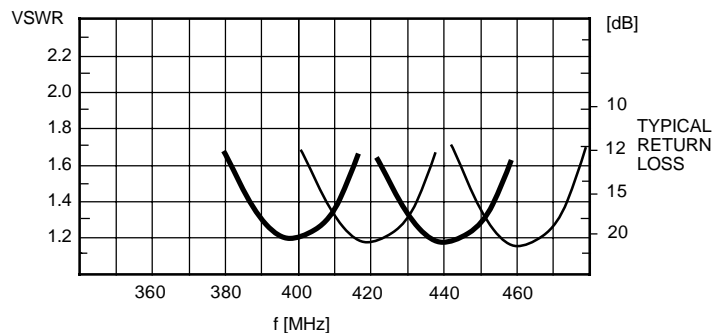

KW 1-08

WIPIC reserves the right to amend specifications in the light of continuing development.

LETRONA AG

Schulstrasse 22, CH-9504 Frittschen
Tel.: +41 071 654 64 64, Fax : +41 071 654 64 65
E-Mail: info@letrona.ch

SQS
Management-System
Zertifiziert ISO 9001: 2000
Reg. - Nr. 11996-03

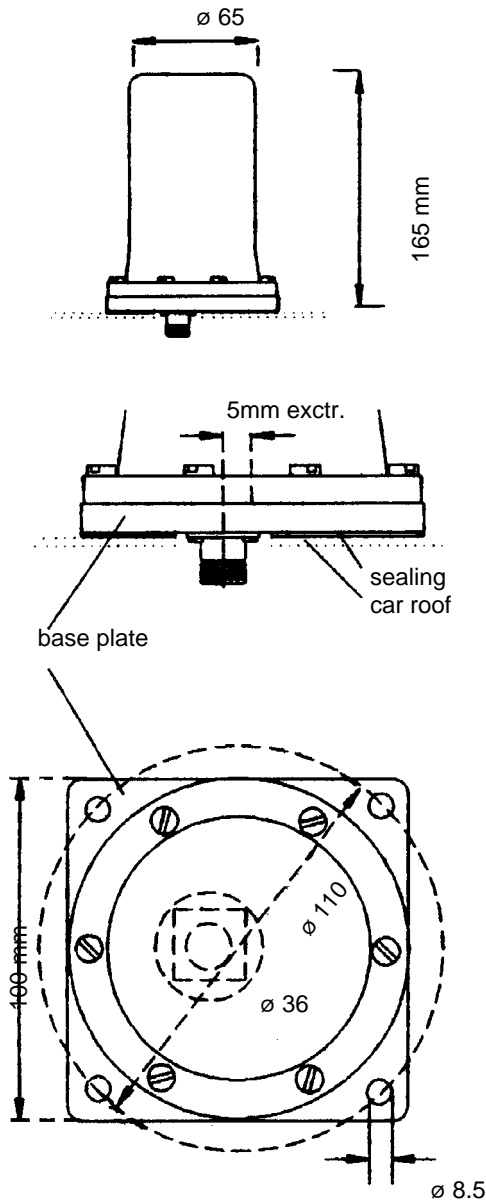

TYPE NO.	WS F40 84 19: 400 - 470 MHz	WS F40 84 18: 370 - 420 MHz
	Tested for rail use according to EN 50388:05	
DESCRIPTION	broadband omnidirectional antenna with radome	
POLARIZATION	vertikal	
IMPEDANCE	50 Ω	
GAIN	0 dB (ref. λ/4 Dipol)	
VSWR	≤ 1.5 at the limits of the band < 1.5	
POWER	150 Watt	
TERMINATION	N chassis female 23 N-50-0-1 other termination on request	
GROUNDING	al metal parts are DC grounded	
MOUNTING	on conductive surface with 1m ² at least	
MATERIAL	aluminium, bolts of stainless steel radome of UV-stabilized polyethylene	
WEIGHT	0.9 kg	
WIND AREA	0.011 m ²	
WIND LOAD	14 N at 150 km/h 10 N at 130 km/h 25 N at 200 km/h	

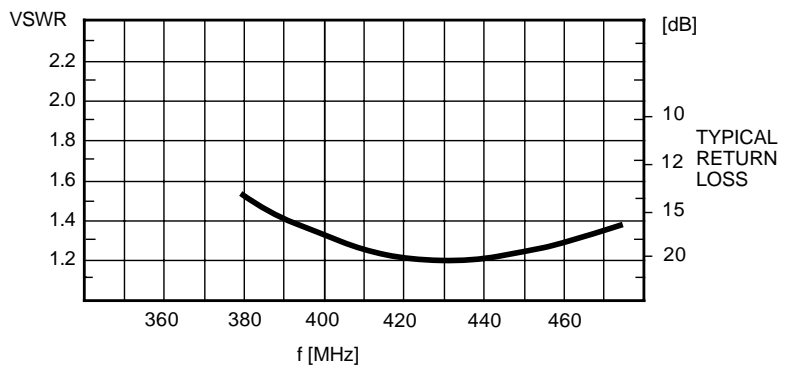

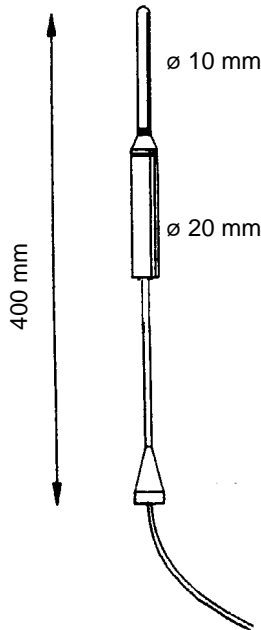

TYPE NO.	WS F60 31 1. 8: 860 - 960 MHz further frequencies on request
DESCRIPTION	The antenna is decoupled from the carrier tube and needs no counter weight. The antenna is specially designed for motorcycles and vehicles with plastic roofs.
POLARIZATION	vertical
IMPEDANCE	50 Ω
GAIN	3 dB (ref. ta a $\lambda/4$ dipole)
VSWR	< 1.5 on tuned frequency
POWER	20 Watt
TERMINATION	1.5 m cable with \varnothing 5mm, without connector the cable must not be shortened (transformer)
GROUNDING	radiator not grounded
MOUNTING	see next page
MATERIAL	anodized aluminium, bolts and spring of stainless steel, rugged plastic base

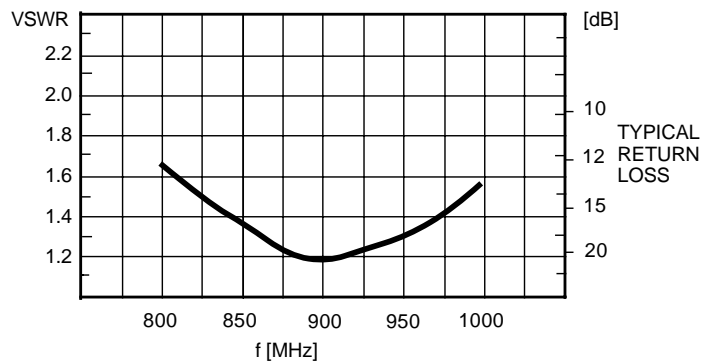

WS F60 31 12 8

with spring



MOUNTING:
on horizontal plane
hole \varnothing 16 mm

WEIGHT: 600 g

WS F60 31 13 8

no longer available

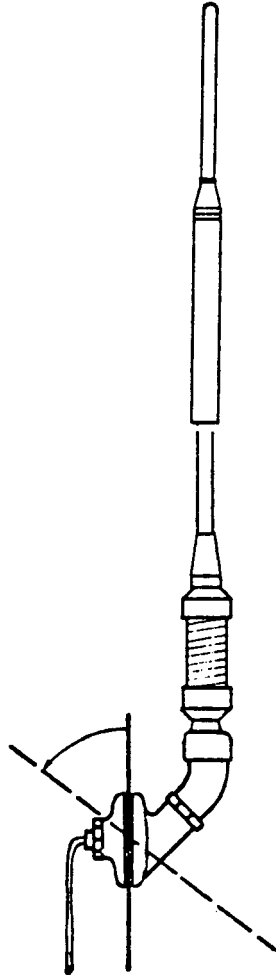

WS F60 31 14 8

with spring and stright
mounting flange



MOUNTING:
on planes with no slope
hole \varnothing 24 mm

WEIGHT: 1000 g

WS F60 31 15 8

with monting clamp

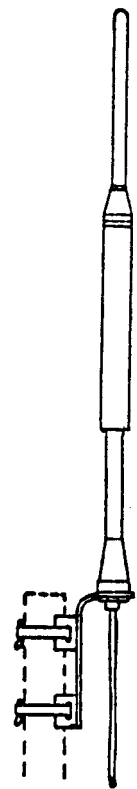

MOUNTING:
on masts, railings etc.
with metallic assembly
line

WEIGHT: 300 g

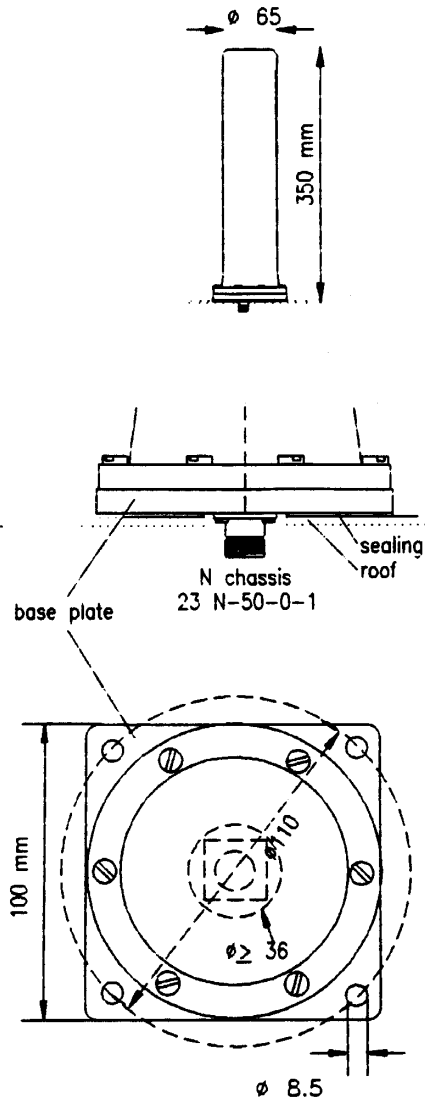

TYPE NO.	WS F60 83 18:	870 - 930 MHz
DESCRIPTION	omnidirectional antenna with radome	
POLARIZATION	vertikal	
IMPEDANCE	50 Ω	
GAIN	3 dB (ref. to a λ/4 dipole)	
VSWR	870 - 930 MHz	≤ 2
	800 - 970 MHz	≤ 4
POWER	150 Watt	
TERMINATION	N chassis female 23 N-50-0-1 other termination on request	
GROUNDING	radiator not DC grounded	
MOUNTING	with four bolts on conductive surface with 0.25m ² at least	
MATERIAL	steel, aluminium, bolts of stainless steel radome of UV-stabilized polyethylene	
WEIGHT	1.0 kg	
WIND AREA	0.023 m ²	
WIND LOAD	29 N at 150 km/h 22 N at 130 km/h 52 N at 200 km/h	

Tested for rail use according to EN 50388:05



RADIATORS TO ANTENNAS FOR RADIATION MEASUREMENTS 30 ... 600 MHz



TYPE	FREQUENCY MHz	LENGTH mm	VSWR on tuned freq.	BANDWIDTH VSWR ≤ 2
WS F1R 65 31	25 ... 58	1700 - 2740	< 1.5	± 2 MHz
WS F2R 65 31	30 ... 75	1020 - 2300	< 1.5	± 4 MHz

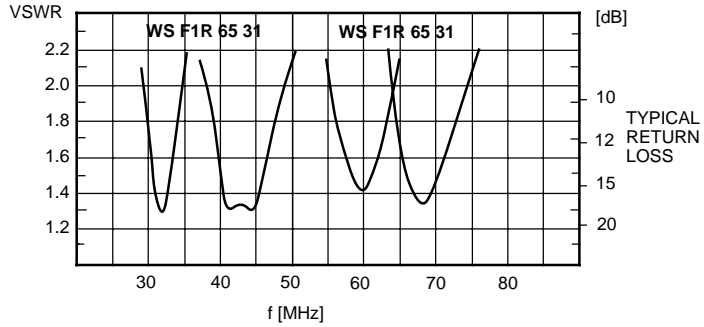

TYPE	FREQUENCY MHz	LENGTH mm	VSWR on tuned freq.	BAND- WIDTH	VSWR
WS F2R 65 21	68 ... 88	1110 - 770	< 2.2	± 5 MHz	< 2
WS FUR 65 21	88 ... 104	770 - 620	< 2.0	± 5 MHz	< 2.2
WS FAR 65 21	104 ... 144	630 - 420	< 1.5	± 10 MHz	< 2
WS F3R 65 21	144 ... 174	435 - 340	< 1.5	± 10 MHz	< 2
WS F3R 65 22	174 ... 235	355 - 240	< 2.0	± 15 MHz	< 2.5
WS F4R 65 21	235 ... 290	250 - 170	< 1.4	± 30 MHz	< 2

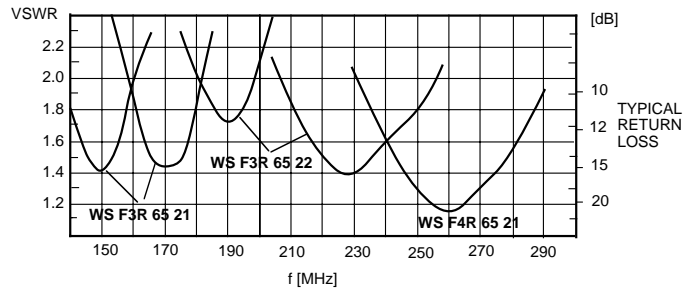
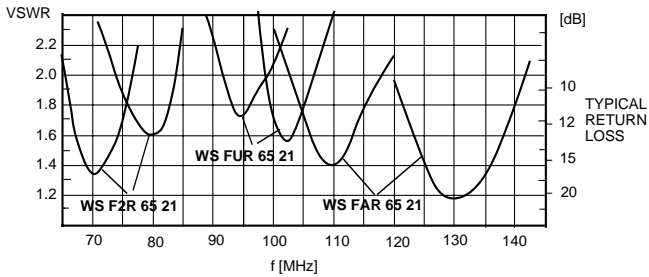

TYPE	FREQUENCY MHz	LENGTH mm	VSWR	BAND- WIDTH	VSWR
WS F4R 65 11	290 - 330	160	< 1.6	280-350 MHz < 2	
WS F4R 65 12	330 - 400	130	< 1.6	320-420 MHz < 2	
WS F4R 65 13	400 - 500	90	< 1.9	390-510 MHz < 2.1	

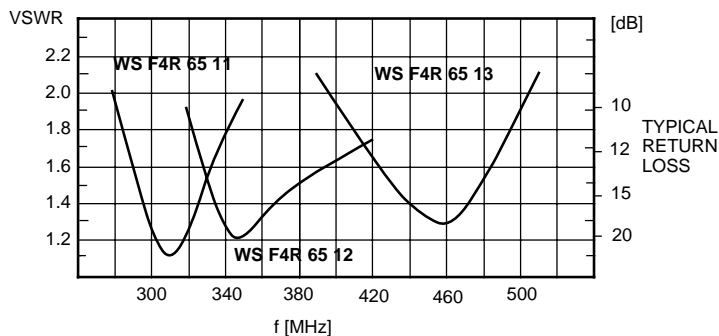



TYPE	FREQUENCY MHz	LENGTH mm	VSWR	BAND-WIDTH	VSWR
WS F4R 65 14	500 - 600	62	< 1.5	480-670 MHz < 2	

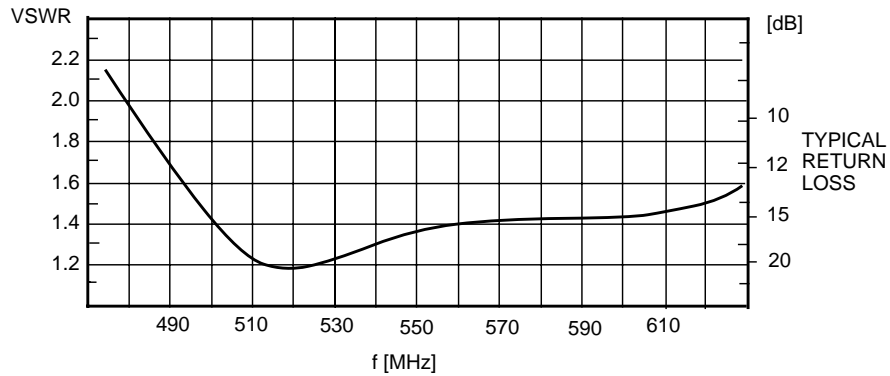

Base for the Radiators WS F0R 65 D

Type:

WS F0R 65 D (replaces WS 01 02 D)

Impedance: 50 Ω

Termination:

1m RG 58 with BNC male
other termination on request

Mounting:

It is important, that the the metallic ring and the roof of the mobile have good electrical contact!
Hole 28+1 mm diameter
On the roof the base shold be sealed with a silicon rubber or the like.

Material:

Aluminium,
insulator: weather resistant plastics

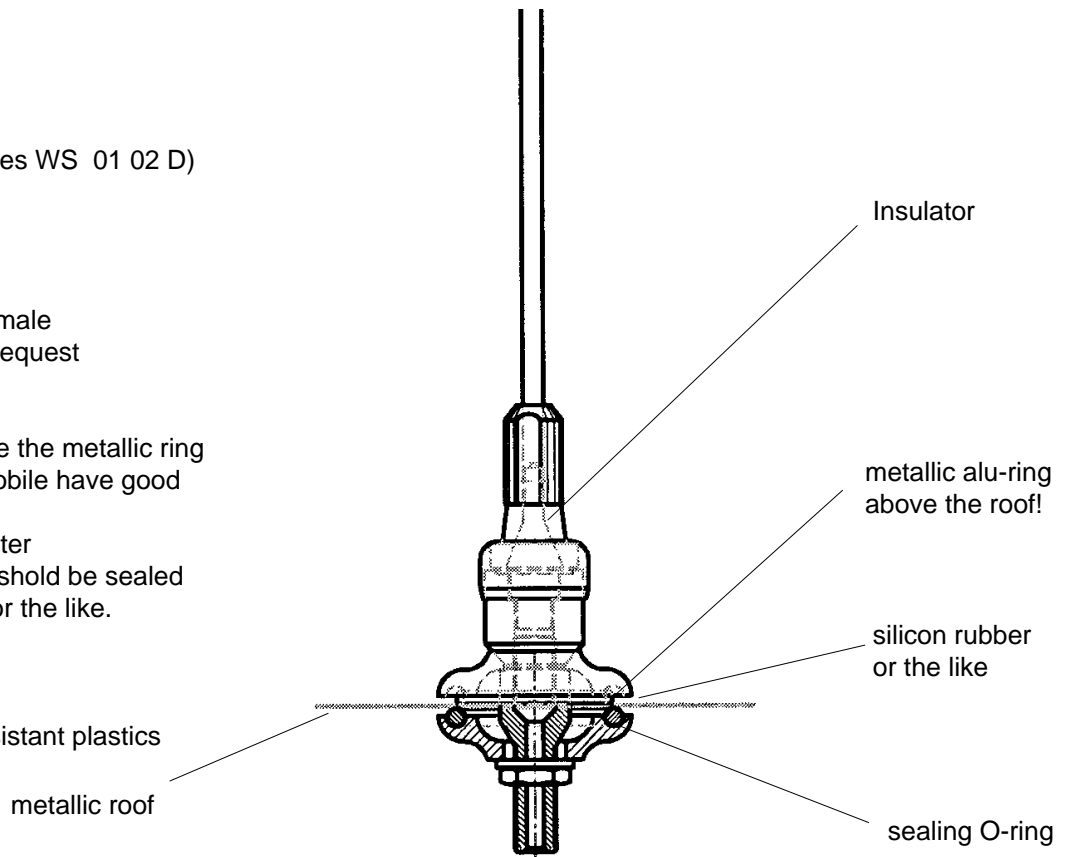

Spring to base WS F0R 65 D

Length: 105 mm without bolts M8
Diameter: 38 mm
Material: aluminium, stainless steel
Weight: ~ 350 g

The spring can be used for the following radiators:
WS F1R 65 31, WS F2R 65 31,
WS F2R 65 21, WS FUR 65 21

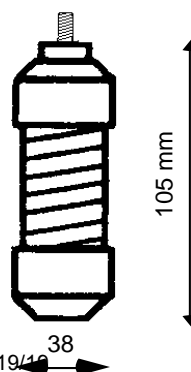

Section 5.

19/19 38