

ORDER NUMBER	ANTENNA TYPE
WS 202 12 .1 .	2 element yagi, light execution without radome
WS 202 13 .1 .	2 element yagi, heavy duty with radome
WS 203 12 .1 .	3 element yagi, light execution without radome
WS 203 13 .1 .	3 element yagi, heavy duty with radome
WS 204 12 .1 .	4 element yagi, light execution without radome
WS 204 13 .1 .	4 element yagi, heavy duty with radome
WS 204 02 12 .	4 element yagi, light execution without radome
WS 204 03 12 .	4 element yagi, heavy duty with radome
WS 206 02 12 .	6 element yagi, light execution without radome
WS 206 03 12 .	6 element yagi, heavy duty with radome
WS 206 02 23 .	6 element yagi, light execution without radome
WS 206 03 23 .	6 element yagi, heavy duty with radome
WS 251 02 11	directional antenna type Kleewi
WS 251 03 11	directional antenna type Kleewi, heavy duty with radome
WS 253 12 13 .	bidirectional, light execution without radome
WS 253 13 13 .	bidirectional, heavy duty with radome
WS .80 22 31 1	logper 87 ... 1000 MHz

## 2 ELEMENT YAGI ANTENNA

WS 202 12 .1 .

68 ... 88 MHz

WS 202 12 11 .

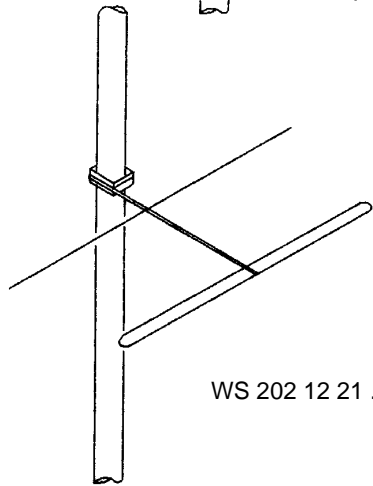
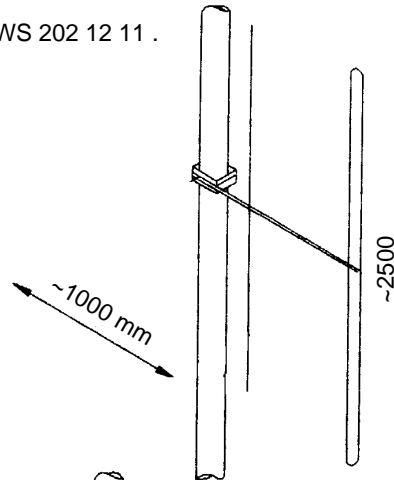

WS 202 12 21 .

**TYPE NO.**

vertical polarization  
**WS 202 12 11 4: 68 - 80 MHz**  
**WS 202 12 11 5: 74 - 88 MHz**  
 horizontal polarization  
**WS 202 12 21 4: 68 - 80 MHz**  
**WS 202 12 21 5: 74 - 88 MHz**  
 further frequencies on request, light execution

**IMPEDANCE**

50 Ω

**GAIN**

2 dB (ref. to λ/2 dipole)

**VSWR**

< 1.3, at the limits of the band < 1.5

**POWER**

250 watts, higher power on request

**3 dB BEAMWIDTH**

in polarization, E-plane: 77°  
 vertical to pol. H-plane: 206°

**TERMINATION**

2 m cable RG 213/U with N male  
 other termination on request

**GROUNDING**

all metal parts are DC grounded

**MOUNTING**

*mast ø*                      *clamp (see chapt. 10)*  
 30 - 80 mm              WG 13 (standard)  
 50 - 104 mm            WG 14 (option)  
 clamps for other mast-ø on request

**MATERIAL**

aluminium, bolts of stainless steel, weather resistant  
 plastics

**WEIGHT**

2.9 kg

**WIND AREA**

0.08 m<sup>2</sup>

**WIND LOAD**

100 N 150 km/h  
 75 N 130 km/h

Radiation  
 Pattern  
 H Plane

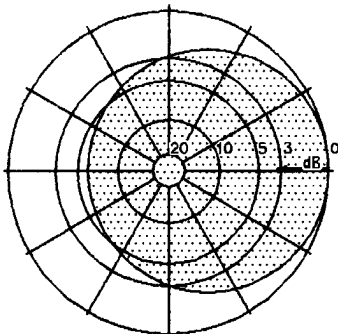

Radiation  
 Pattern  
 E Plane

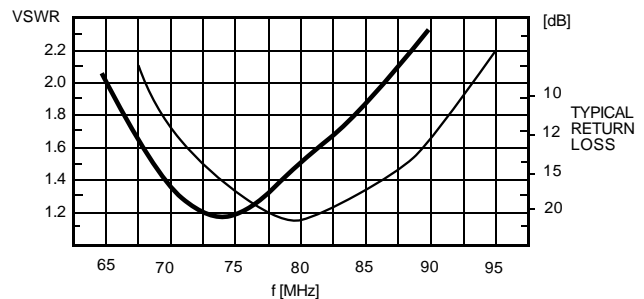
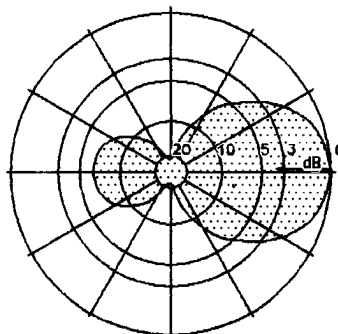

WIPIC reserves the right to amend specifications in the light of continuing development.

KW 1-08

**LETRONA AG**

Schulstrasse 22, CH-9504 Frittschen  
 Tel.: +41 (0)71 654 64 64, Fax : +41 (0)71 654 64 65  
 E-Mail: info@letrona.ch

WS 202 13 11 .

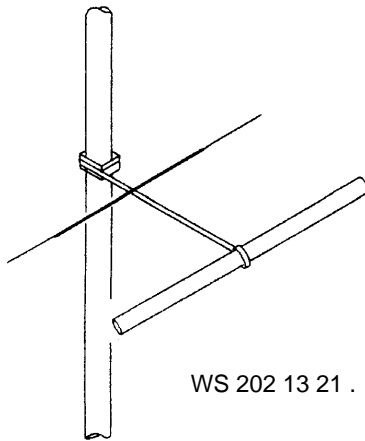
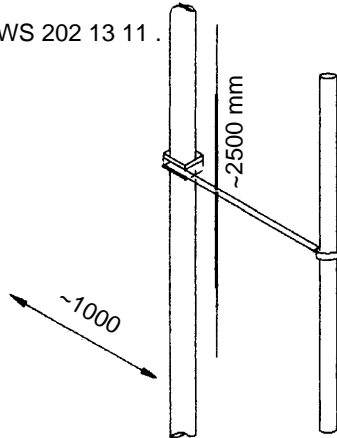

**TYPE NO.** vertical polarization  
**WS 202 13 11 4: 68 - 80 MHz**  
**WS 202 13 11 5: 74 - 88 MHz**  
 horizontal polarization  
**WS 202 13 21 4: 68 - 80 MHz**  
**WS 202 13 21 5: 74 - 88 MHz**  
 further frequencies on request

**DESCRIPTION** heavy duty, with radom  
 The radom protects the antenna dipole against environmental influences, icing, and increases the lightning protection.

**IMPEDANCE** 50 Ω

**GAIN** 2 dB (ref. to λ/2 dipole)

**VSWR** < 1.3, at the limits of the band < 1.5

**POWER** 250 watts, higher power on request

**3 dB BEAMWIDTH** in polarization, E-plane: 77°  
 vertical to pol. H-plane: 206°

**TERMINATION** 2 m cable RG 213/U with N male  
 other termination on request

**GROUNDING** all metal parts are DC grounded

**MOUNTING** mast ø clamp (see chapt. 10)  
 30 - 80 mm WG 17 (standard)  
 50 - 104 mm WG 18 (option)  
 clamps for other mast-ø on request

**MATERIAL** aluminium, bolts of stainless steel, radom of UV-stabilized polyethylene

**WEIGHT** 4.5 kg  
**WIND AREA** 0.2 m<sup>2</sup>  
**WIND LOAD** 255 N 150 km/h  
 192 N 130 km/h

Radiatio  
 Pattern  
 H Plane

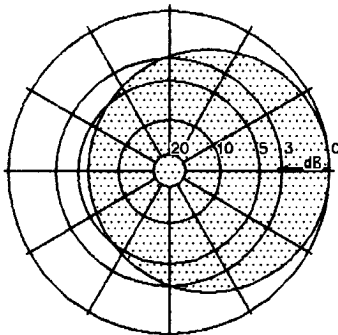

Radiatio  
 Pattern  
 E Plane

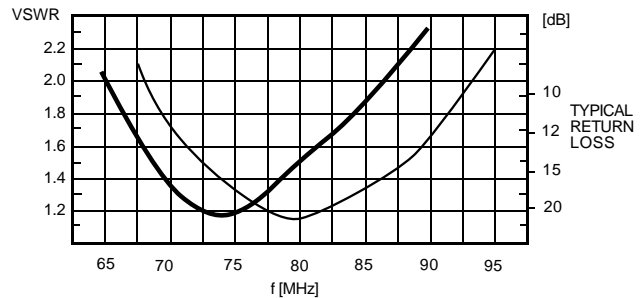
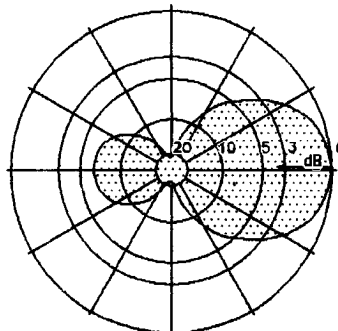

WIPIC reserves the right to amend specifications in the light of continuing development.

WS 203 12 11 .

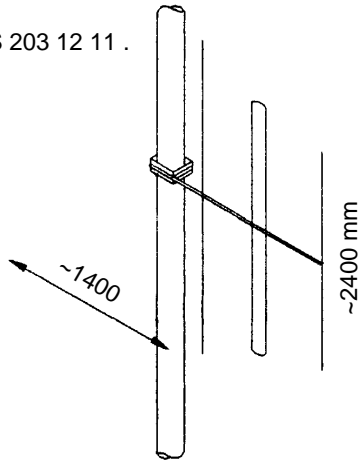

**TYPE NO.**

vertical polarization

**WS 203 12 11 4: 68 - 80 MHz**

**WS 203 12 11 5 : 74 - 88 MHz**

horizontal polarization

**WS 203 12 21 4: 68 - 80 MHz**

**WS 203 12 21 5 : 74 - 88 MHz**

further frequencies on request, light execution

**IMPEDANCE**

50  $\Omega$

**GAIN**

3 dB (ref. to  $\lambda/2$  dipole)

**VSWR**

< 1.3, at the limits of the band < 1.5

**POWER**

250 watts

**3 dB BEAMWIDTH**

in polarization, E-plane: 72°  
vertical to pol. H-plane: 160°

**TERMINATION**

2 m cable RG 213/U with N male  
other termination on request

**GROUNDING**

all metal parts are DC grounded

**MOUNTING**

*mast  $\varnothing$*       *clamp (see chapt. 10)*

30 - 80 mm    WG 13 (standard)

50 - 104 mm   WG 14 (option)

**MATERIAL**

aluminium, bolts of stainless steel, radom of UV-stabilized polyethylene

**WEIGHT**

3.1 kg

**WIND AREA**

0.16 m<sup>2</sup>

**WIND LOAD**

204 N 150 km/h

153 N 130 km/h

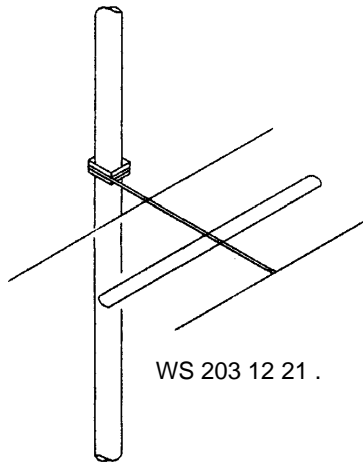

WS 203 12 21 .

Radiation  
Pattern  
H Plane

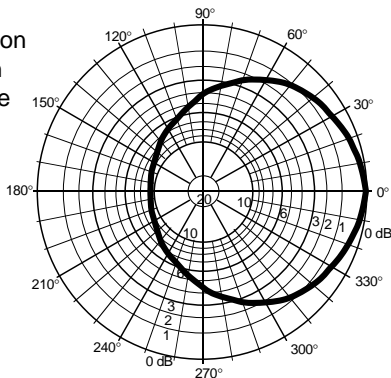

Radiation  
Pattern  
E Plane

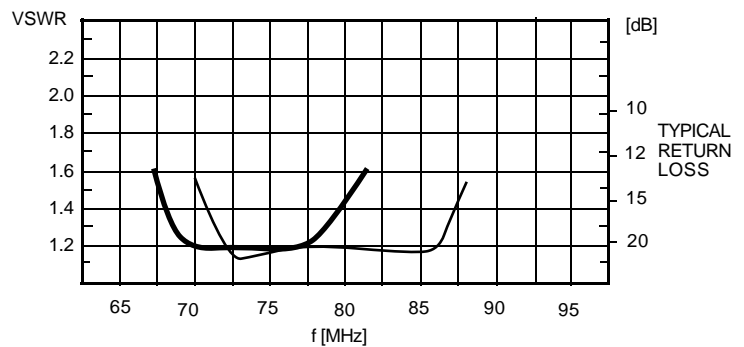
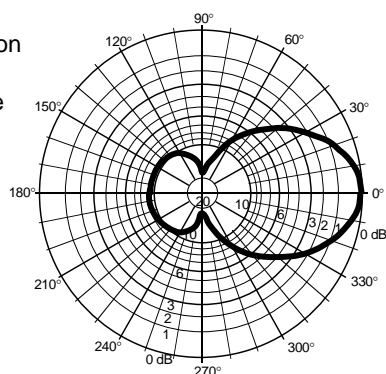

KW 1-08

WIPIC reserves the right to amend specifications in the light of continuing development.

## 3 ELEMENT YAGI ANTENNA

WS 203 13 .1 .

68 ... 88 MHz

**TYPE NO.**

vertical polarization  
**WS 203 13 11 4: 68 - 80 MHz**  
**WS 203 13 11 5 : 74 - 88 MHz**  
 horizontal polarization  
**WS 203 13 21 4: 68 - 81 MHz**  
**WS 203 13 21 5 : 74 - 88 MHz**  
 further frequencies on request

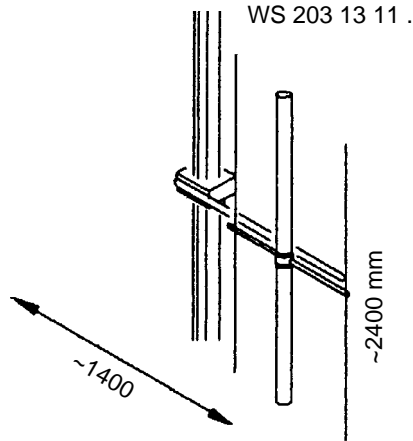

**DESCRIPTION**

heavy duty, with radom  
 The radom protects the antenna dipole against environmental influences, icing, and increases the lightning protection.

**IMPEDANCE**

50 Ω

**GAIN**

3 dB (ref. to λ/2 dipole)

**VSWR**

< 1.3, at the limits of the band < 1.5

**POWER**

250 watts

**3 dB BEAMWIDTH**

in polarization, E-plane: 72°  
 vertical to pol. H-plane: 160°

**TERMINATION**

2 m cable RG 213/U with N male  
 other termination on request

**GROUNDING**

all metal parts are DC grounded

**MOUNTING**

*mast* ∅      *clamp* (see chapt. 10)  
 30 - 80 mm    WG 17 (standard)  
 50 - 104 mm   WG 18 (option)

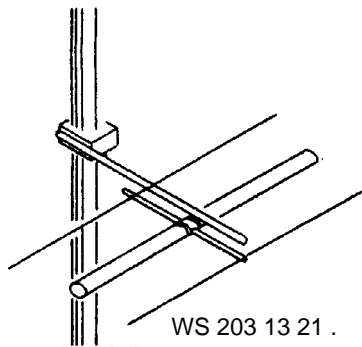

**MATERIAL**

aluminium, bolts of stainless steel, radom of UV-stabilized polyethylene

**WEIGHT**

7.2 kg

**WIND AREA**

0.31 m<sup>2</sup>

**WIND LOAD**

395 N 150 km/h  
 295 N 130 km/h

Radiation Pattern H Plane

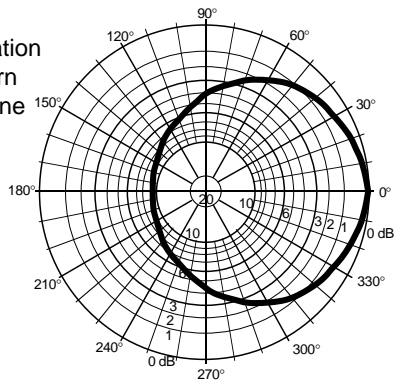

Radiation Pattern E Plane

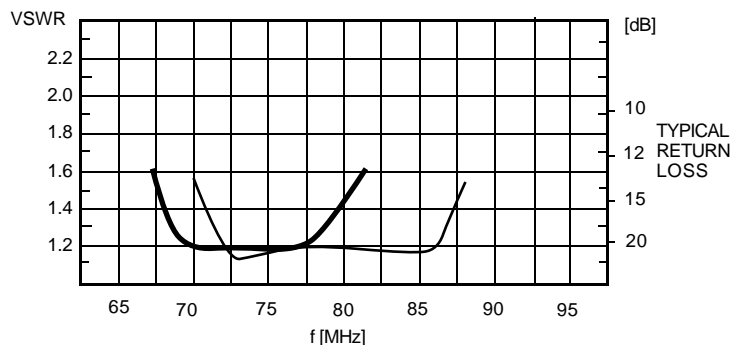
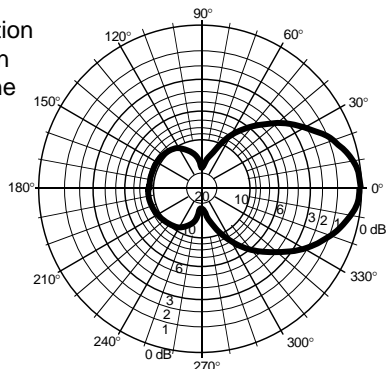

KW 1-08

WIPIC reserves the right to amend specifications in the light of continuing development.

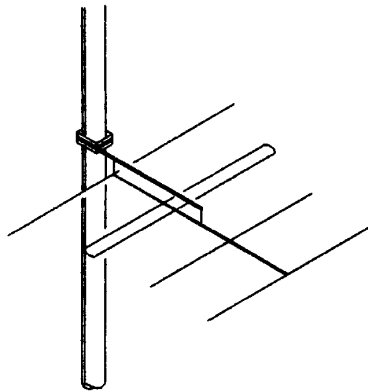
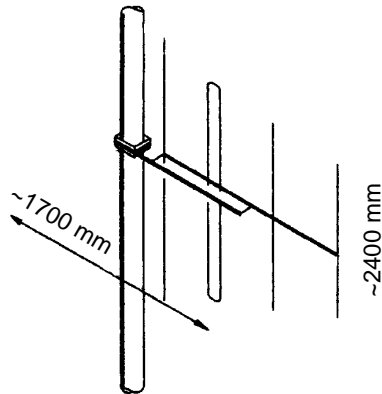

<b>TYPE NO.</b>	vertical polarization <b>WS 204 12 11 4: 68 - 82 MHz</b> <b>WS 204 12 11 5: 72 - 88 MHz</b>
	horizontal polarization <b>WS 204 12 21 4: 68 - 82 MHz</b> <b>WS 204 12 21 5: 72 - 88 MHz</b> further frequencies on request, light execution
<b>IMPEDANCE</b>	50 Ω
<b>GAIN</b>	3.5 - 5 dB (ref. to λ/2 dipole)
<b>VSWR</b>	< 1.3, at the limits of the band < 1.5
<b>POWER</b>	max. 250 watts
<b>3 dB BEAMWIDTH</b>	in polarization, E-plane: 67° vertical to pol. H-plane: 126°
<b>TERMINATION</b>	2 m cable RG 213/U ending with N male other termination on request
<b>GROUNDING</b>	all metal parts are DC grounded
<b>MOUNTING</b>	<i>mast ø</i> <i>clamp (see chapt. 10)</i> 30 - 80 mm              WG 15 (standard) 50 - 104 mm            WG 16 (option) clamp for other mast ø on request
<b>MATERIAL</b>	aluminium, bolts of stainless steel, weather-resistant plastic
<b>WEIGHT</b>	3.4 kg
<b>WIND AREA</b>	0.19 m <sup>2</sup>
<b>WIND LOAD</b>	250 N 150 km/h 185 N 130 km/h

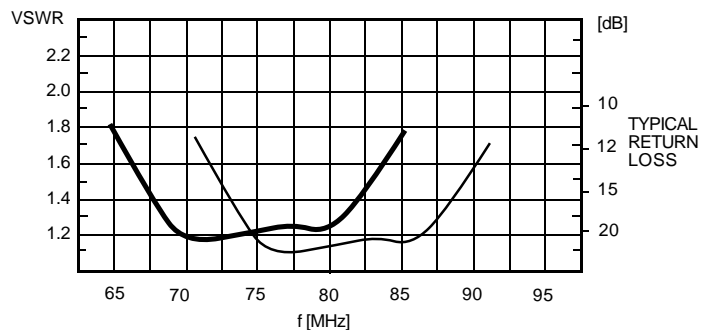
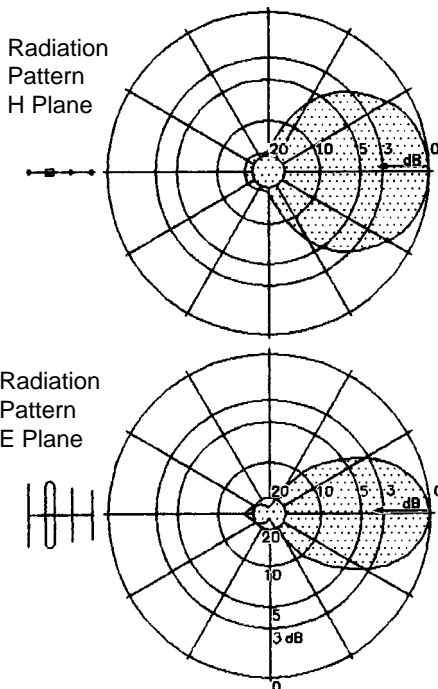

KW 1-08

WIPIC reserves the right to amend specifications in the light of continuing development.

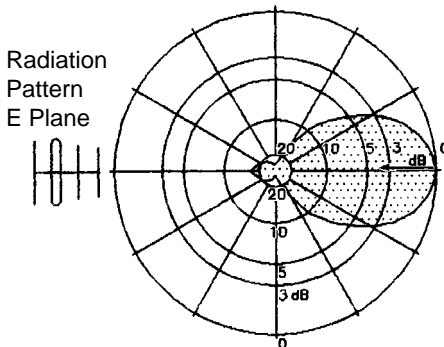
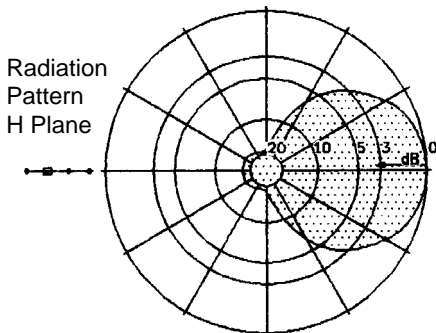
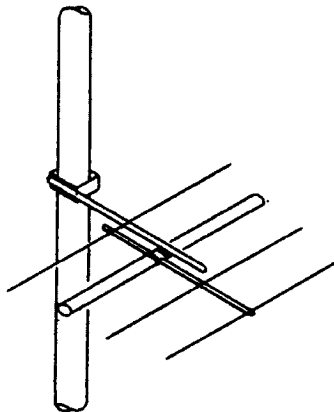
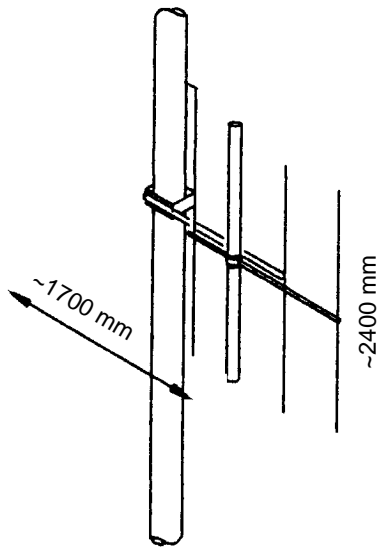

<b>TYPE NO.</b>	vertical polarization
	<b>WS 204 13 11 4: 68 - 81 MHz</b> <b>WS 204 13 11 5: 72 - 88 MHz</b>
<b>DESCRIPTION</b>	horizontal polarization
	<b>WS 204 13 21 4: 68 - 81 MHz</b> <b>WS 204 13 21 5: 72 - 88 MHz</b>
	further frequencies on request
<b>IMPEDANCE</b>	50 Ω
<b>GAIN</b>	3.5 - 5 dB (ref. to λ/2 dipole)
<b>VSWR</b>	< 1.3, at the limits of the band < 1.5
<b>POWER</b>	250 watts, higher power on request
<b>3 dB BEAMWIDTH</b>	in polarization, E-plane: 67° vertical to pol. H-plane: 126°
<b>TERMINATION</b>	2 m cable RG 213/U with N male other termination on request
<b>GROUNDING</b>	all metal parts are DC grounded
<b>MOUNTING</b>	<i>mast</i> ∅ <i>clamp</i> (see chapt. 10) 30 - 80 mm    WG 17 (standard) 50 - 104 mm   WG 18 (option) other clamp on request
<b>MATERIAL</b>	aluminium, bolts of stainless steel, radom of UV-stabilized polyethylene

<b>WEIGHT</b>	8 kg
<b>WIND AREA</b>	0.35 m <sup>2</sup>
<b>WIND LOAD</b>	450 N 150 km/h 340 N 130 km/h

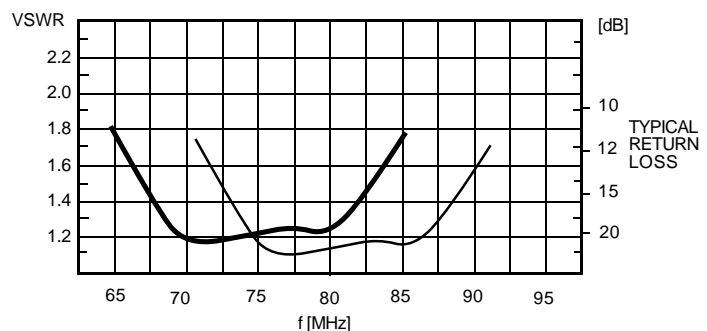

## 4- ELEMENT YAGI ANTENNA

WS 204 02 12 .

68 ... 88 MHz

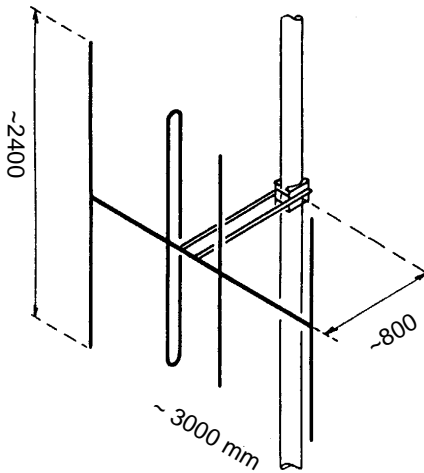

**TYPE NO.** WS 204 02 12 6: 68 - 73 MHz  
 WS 204 02 12 7: 73 - 78 MHz  
 WS 204 02 12 8: 78 - 84 MHz  
 WS 204 02 12 9: 83 - 88 MHz  
 further frequencies on request, light execution

**POLARIZATION** vertical  
**IMPEDANCE** 50 Ω  
**GAIN** 6 dB (ref. to λ/2 dipole)  
**VSWR** < 1.3 at the limits of the band < 1.5  
**POWER** max. 250 watts, higher power on request

**3 dB BEAMWIDTH** horizontal, H-plane: 100°  
 vertical, E-plane: 50°

**TERMINATION** 2 m cable RG 213/U ending with N male  
 other termination on request

**GROUNDING** all metal parts are DC grounded

**MOUNTING** mast ø clamp (see chapt. 10)  
 30 - 80 mm WG 55 (standard)  
 50 - 104 mm WG 56 (option)  
 clamp for other ø on request

**MATERIAL** aluminium, bolts of stainless steel, weather-resistant plastic

**WEIGHT** 4 kg  
**WIND AREA** 0.3 m<sup>2</sup>  
**WIND LOAD** 450 N 150 km/h  
 340 N 130 km/h

Horizontal Radiation Pattern H Plane

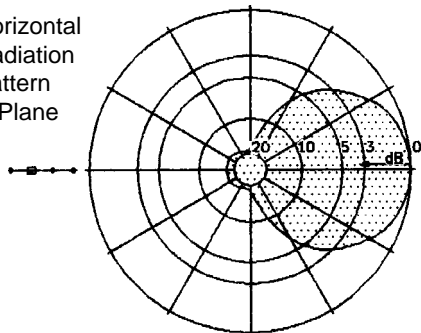

Vertical Radiation Pattern E Plane

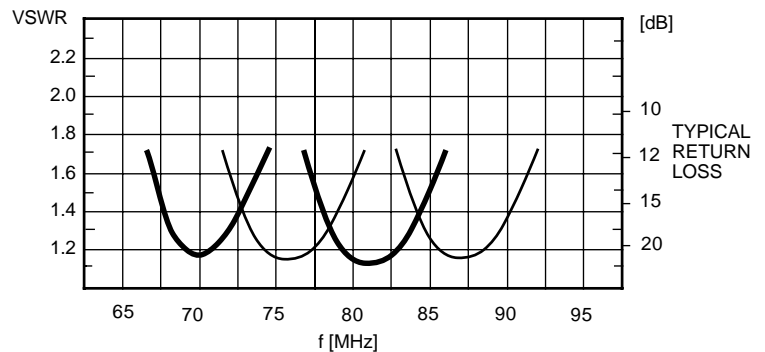
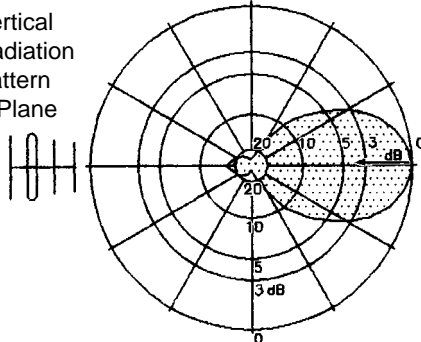

KW 1-08

WIPIC reserves the right to amend specifications in the light of continuing development.

# 4-ELEMENT YAGI ANTENNA

WS 204 03 12 .

68 ... 88 MHz

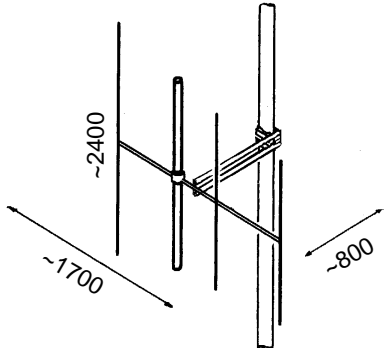

**TYPE NO.** WS 204 03 12 6: 68 - 73 MHz  
 WS 204 03 12 7: 73 - 78 MHz  
 WS 204 03 12 8: 78 - 84 MHz  
 WS 204 03 12 9: 83 - 88 MHz  
 further frequencies on request

**DESCRIPTION** heavy duty, with radome  
 The radom protects the antenna dipole against environmental influences, icing, and increases the lightning protection.

**POLARIZATION** vertical

**IMPEDANCE** 50 Ω

**GAIN** 6 dB (ref. to λ/2 dipole)

**VSWR** < 1.3

**POWER** 250 watts

**3 dB BEAMWIDTH** horizontal, H-plane: 100°  
 vertical, E-plane: 50°

**TERMINATION** 2 m cable RG 213/U with N male  
 other termination on request

**GROUNDING** all metal parts are DC grounded

**MOUNTING** mast ø clamp (see chapt. 10)  
 30 - 80 mm WG 63 (standard)  
 50 - 104 mm WG 64 (option)  
 clamp for other o on request

**MATERIAL** aluminium, bolts of stainless steel, radom of UV-stabilized polyethylene

**WEIGHT** 8 kg  
**WIND AREA** 0.35 m<sup>2</sup>  
**WIND LOAD** 450 N 150 km/h  
 340 N 130 km/h

Horizontal Radiation Pattern H Plane

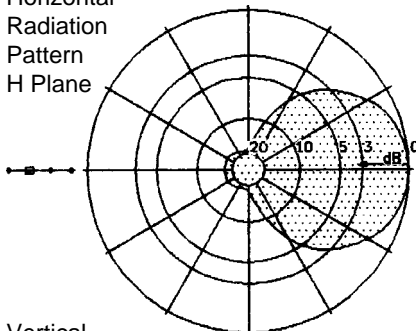

Vertical Radiation Pattern E Plane

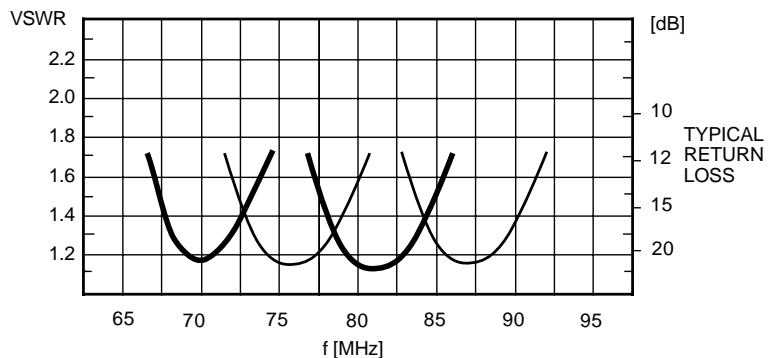
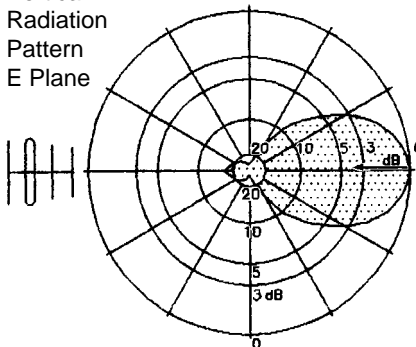

KW 1-08

WIPIC reserves the right to amend specifications in the light of continuing development.

## 6- ELEMENT YAGI ANTENNA

WS 206 02 12 .

68 ... 88 MHz

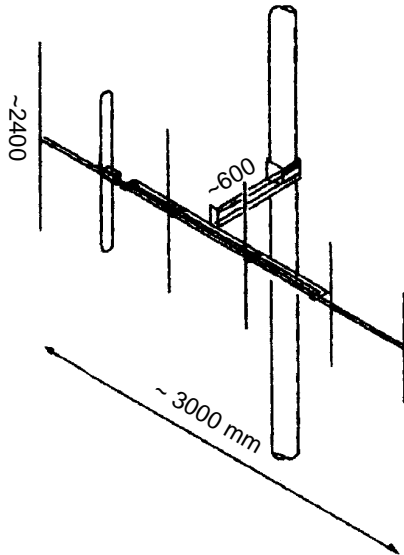

**TYPE NO.** WS 206 02 12 8: 68 - 78 MHz  
 WS 206 02 12 9: 78 - 88 MHz  
 further frequencies on request, light execution

**POLARIZATION** vertical

**IMPEDANCE** 50 Ω

**GAIN** 8.5 dB (ref. to λ/2 dipole)

**VSWR** < 1.3 at the limits of the band < 1.5

**POWER** max. 250 watts, higher power on request

**3 dB BEAMWIDTH** horizontal, H-plane: 70°  
 vertical, E-plane: 48°

**TERMINATION** 2 m cable RG 213/U ending with N male  
 other termination on request

**GROUNDING** all metal parts are DC grounded

**MOUNTING** mast ø clamp (see chapt. 10)  
 30 - 80 mm WG 55 (standard)  
 50 - 104 mm WG 56 (option)  
 clamp for other ø on request

**MATERIAL** aluminium, bolts of stainless steel, weather-resistant plastic

**WEIGHT** 5.5 kg  
**WIND AREA** 0.3 m<sup>2</sup>  
**WIND LOAD** 220 N 150 km/h  
 160 N 130 km/h

Horizontal  
 Radiation  
 Pattern  
 H Plane

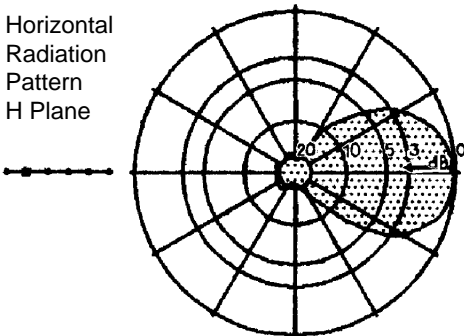

Vertical  
 Radiation  
 Pattern  
 E Plane

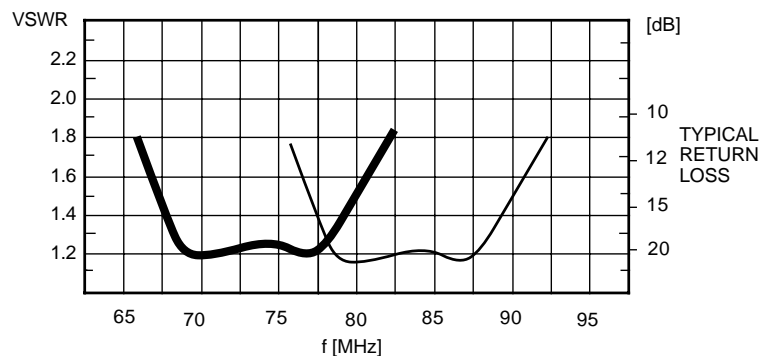
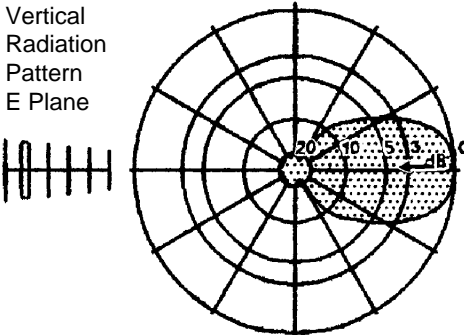

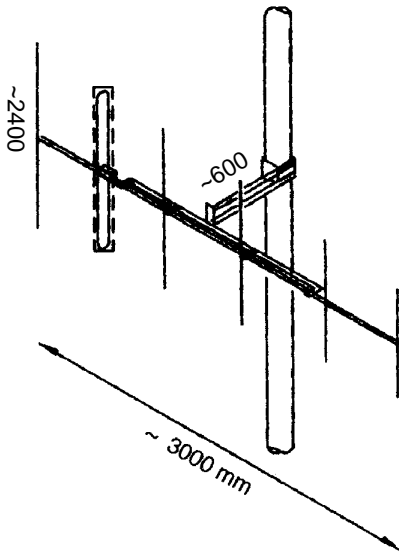

**TYPE NO.** WS 206 03 12 8: 68 - 78 MHz  
 WS 206 03 12 9: 78 - 88 MHz  
 further frequencies on request

**DESCRIPTION** heavy duty, with radom  
 The radom protects the antenna dipol against environmental influences, icing, and increases the lightning protection.

**POLARIZATION** vertical

**IMPEDANCE** 50 Ω

**GAIN** 8.5 dB (ref. to λ/2 dipole)

**VSWR** < 1.3

**POWER** 250 watts

**3 dB BEAMWIDTH** horizontal, H-plane: 70°  
 vertical, E-plane: 48°

**TERMINATION** 2 m cable RG 213/U with N male  
 other termination on request

**GROUNDING** all metal parts are DC grounded

**MOUNTING** mast ø clamp (see chapt. 10)  
 30 - 80 mm WG 63 (standard)  
 50 - 104 mm WG 64 (option)  
 clamp for other o on request

**MATERIAL** aluminium, bolts of stainless steel, radom of UV-stabilized polyethylene

**WEIGHT** 8 kg  
**WIND AREA** 0.35 m<sup>2</sup>  
**WIND LOAD** 450 N 150 km/h  
 340 N 130 km/h

Horizontal Radiation Pattern H Plane

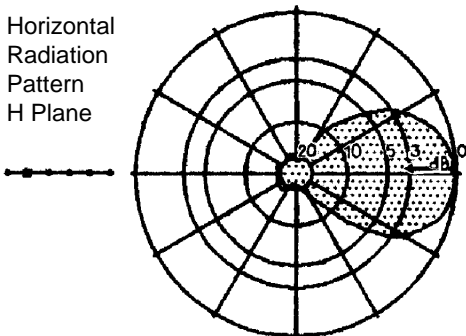

Vertical Radiation Pattern E Plane

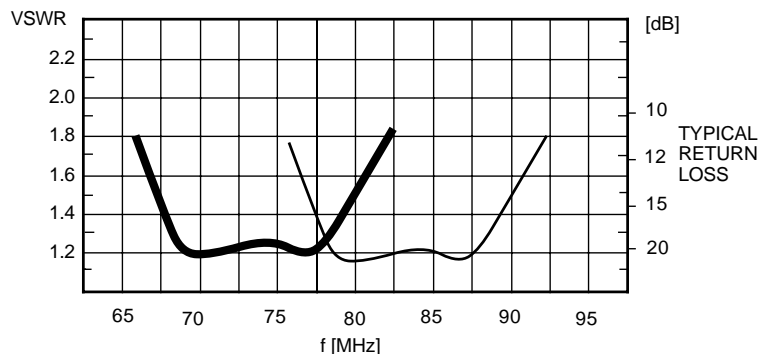
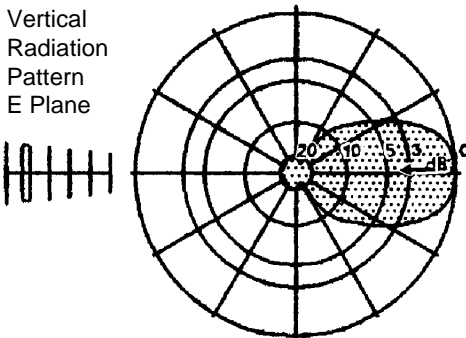

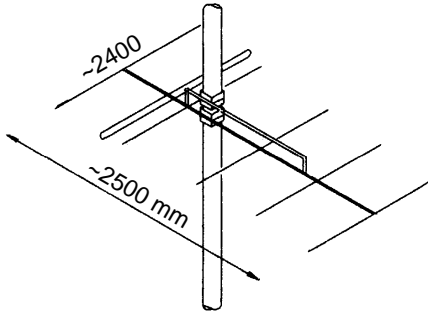

**TYPE NO.** WS 206 02 23 8: 68 - 78 MHz  
 WS 206 02 23 9: 78 - 88 MHz  
 further frequencies on request, light execution

**POLARIZATION** horizontal

**IMPEDANCE** 50 Ω

**GAIN** 8 dB (ref. to λ/2 dipole)

**VSWR** < 1.3, at the limits of the band < 1.5

**POWER** max. 250 watts, higher power on request

**3 dB BEAMWIDTH** horizontal H-plane: 50°  
 vertical E-plane: 80°

**TERMINATION** 2 m cable RG 213/U ending with N male  
 other termination on request

**GROUNDING** all metal parts are DC grounded

**MOUNTING** mast ø clamp (see chapt. 10)  
 30 - 80 mm WG 11 (standard)  
 50 - 104 mm WG 12 (option)  
 clamp for other mast ø on request

**MATERIAL** aluminium, bolts of stainless steel, weather-resistant plastic

**WEIGHT** 3.4 kg  
**WIND AREA** 0.17 m<sup>2</sup>  
**WIND LOAD** 220 N 150 km/h  
 160 N 130 km/h

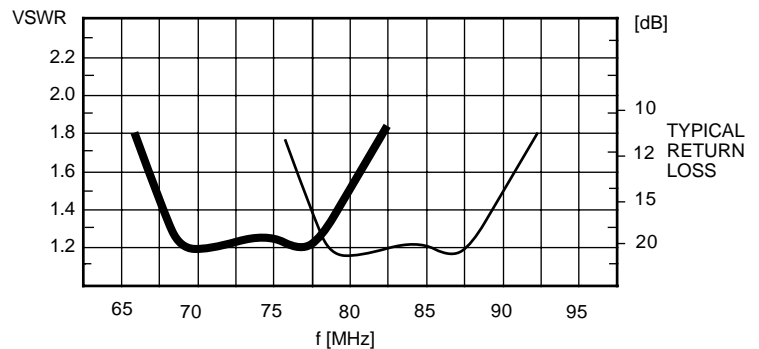
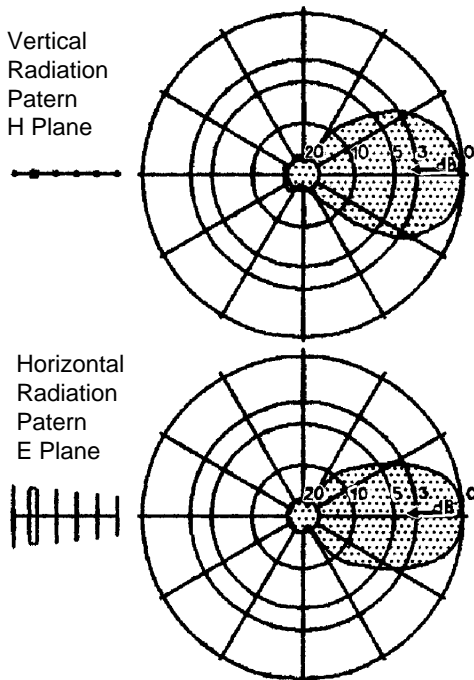

KW 1-08

WIPIC reserves the right to amend specifications in the light of continuing development.

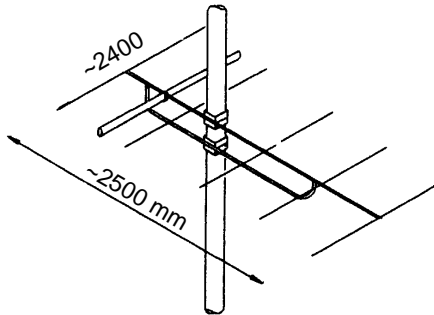

<b>TYPE NO.</b>	<b>WS 206 03 23 8: 68 - 78 MHz</b> <b>WS 206 03 23 9: 78 - 88 MHz</b> further frequencies on request
<b>DESCRIPTION</b>	heavy duty, with radom The radom protects the antenna dipol against environmental influences, icing, and increases the lightning protection.
<b>POLARIZATION</b>	horizontal
<b>IMPEDANCE</b>	50 Ω
<b>GAIN</b>	8 dB (ref. to λ/2 dipole)
<b>VSWR</b>	< 1.3
<b>POWER</b>	250 watts, higher power on request
<b>3 dB BEAMWIDTH</b>	in polarization, E-plane: 50° vertical to pol. H-plane: 80°
<b>TERMINATION</b>	2 m cable RG 213/U with N male other termination on request
<b>GROUNDING</b>	all metal parts are DC grounded
<b>MOUNTING</b>	<i>mast</i> ∅ <i>clamp</i> (see chapt. 10) 30 - 80 mm    WG 13 (standard) 50 - 104 mm   WG 14 (option) other clamp on request
<b>MATERIAL</b>	aluminium, bolts of stainless steel, radom of UV-stabilized polyethylene
<b>WEIGHT</b>	9 kg
<b>WIND AREA</b>	0.34 m <sup>2</sup>
<b>WIND LOAD</b>	435 N 150 km/h 325 N 130 km/h

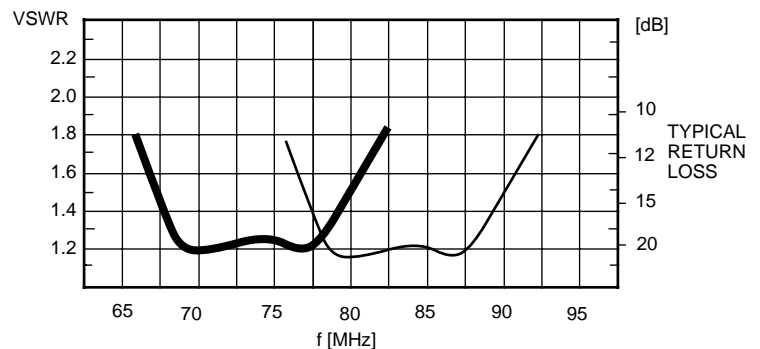
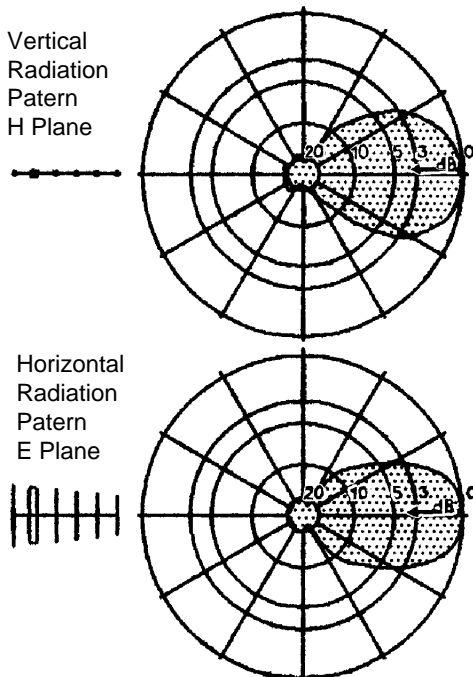

KW 1-08

WIPIC reserves the right to amend specifications in the light of continuing development.

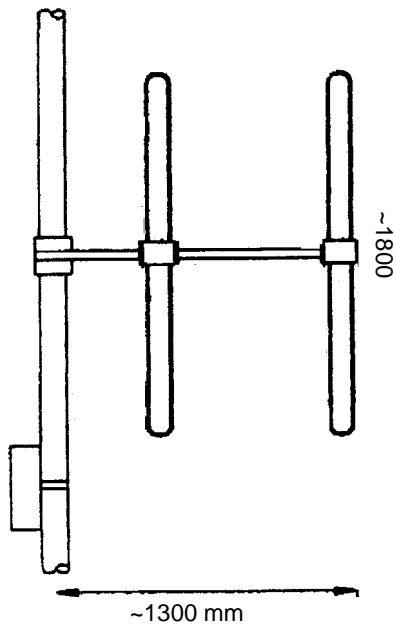

<b>TYPE NO.</b>	<b>WS 251 02 11 : (desired frequency)</b> The antenna is tuned to the desired frequency in the band 68 - 88 MHz further frequencies on request, light execution
<b>DESCRIPTION</b>	This antenna produces various radiation patterns and f/b ratios, see figures
<b>POLARIZATION</b>	vertical
<b>IMPEDANCE</b>	50 Ω
<b>GAIN</b>	3 dB (ref. λ/2 dipole)
<b>VSWR</b>	< 1.3, at the limits of the band <1.4
<b>POWER</b>	max. 350 watts, higher power on request
<b>3 dB BEAMWIDTH</b>	horizontal: see radiation patterns vertical: ~ 78°
<b>TERMINATION</b>	in the junction box WAK1 ending with N male other termination on request
<b>GROUNDING</b>	all metal parts are DC grounded
<b>MOUNTING</b>	<i>mast-ø</i> <i>clamp</i> 30 - 80 mm                WG 17 (standard) 50 - 104 mm              WG 18 (option) clamp for other mast-ø on request

**TYPICAL RADIATION PATTERNS**  
**H-Plane**

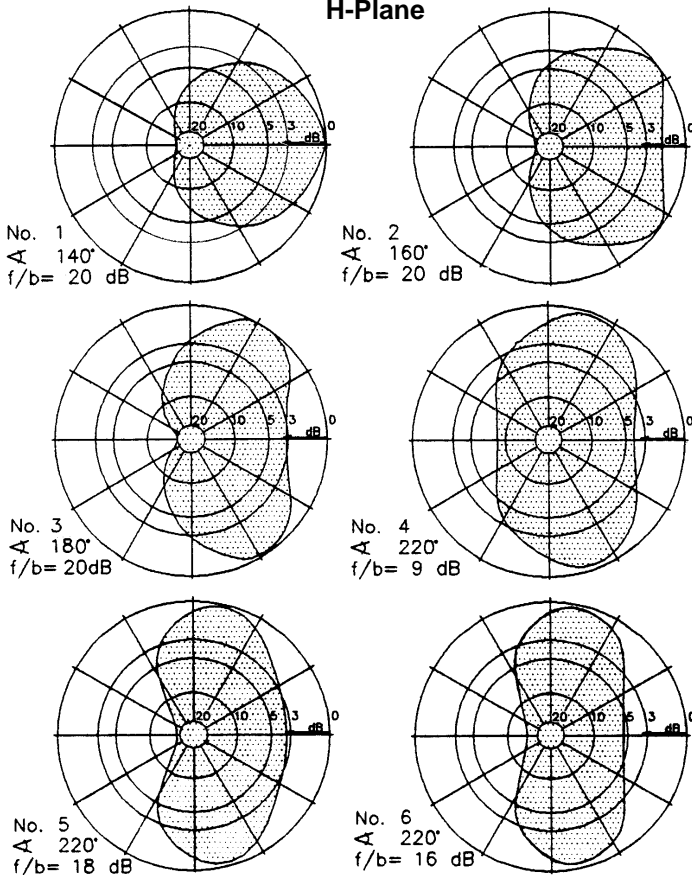

<b>MATERIAL</b>	aluminium, bolts of stainless steel, weather-resistant plastics
<b>WEIGHT</b>	5 kg
<b>WIND AREA</b>	0.2 m <sup>2</sup>
<b>WIND LOAD</b>	255 N (150 km/h) 190 N (130 km/h)

WIPIC reserves the right to amend specifications in the light of continuing development.

KW 1-08

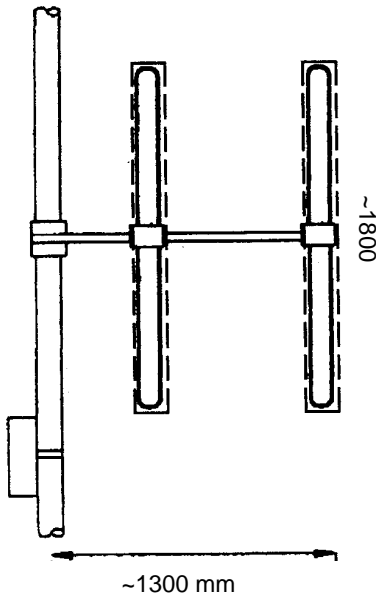

**TYPE NO.**

**WS 251 03 11 : (desired frequency)**

The antenna is tuned to the desired frequency in the band 68 - 87.5 MHz  
further frequencies on request

**DESCRIPTION**

heavy duty, with radome  
The radome protects the antenna dipole against environmental influences, icing, and increases the lightning protection.  
This antenna produces various radiation patterns and f/b ratios, see figures.

**POLARIZATION**

vertical

**IMPEDANCE**

50 Ω

**GAIN**

3 dB (ref. λ/2 dipole)

**VSWR**

< 1.3, at the limits of the band <1.4

**POWER**

max. 350 watts, higher power on request

**3 dB BEAMWIDTH**

horizontal: see radiation patterns  
vertical: ~ 78°

**TERMINATION**

in the junction box WAK1 ending with N male  
other termination on request

**GROUNDING**

all metal parts are DC grounded

**TYPICAL RADIATION PATTERNS**

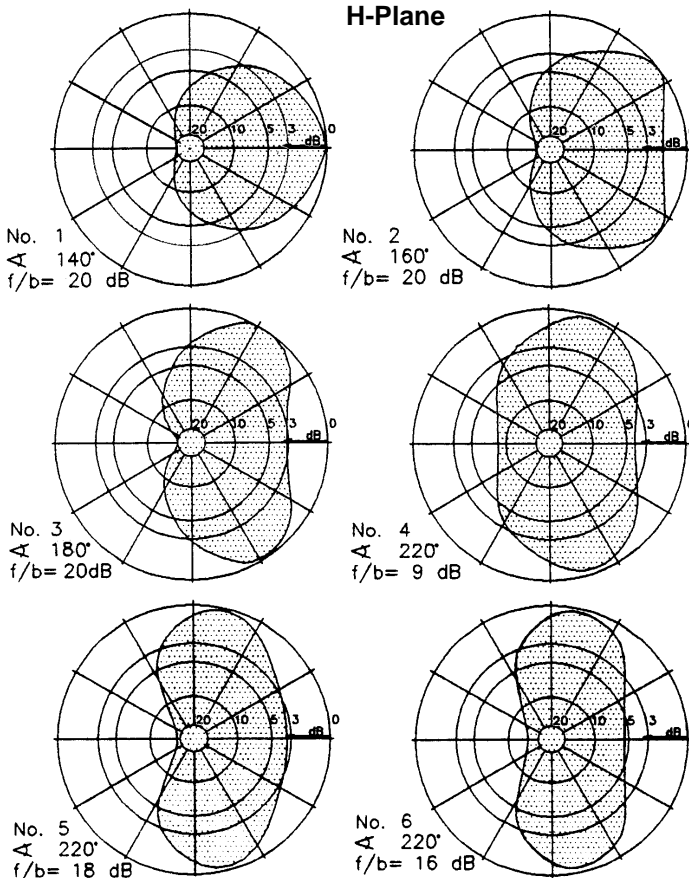

**MOUNTING**

*mast-ø*      *clamp (chapt. 10)*  
30 - 80 mm    WG 17 (standard)  
50 - 104 mm   WG 18 (option)  
clamp for other mast-ø on request

**MATERIAL**

aluminium, bolts of stainless steel, UV-stabilized PE

**WEIGHT**

21 kg

**WIND AREA**

0.56 m<sup>2</sup>

**WIND LOAD**

715 N (150 km/h)  
540 N (130 km/h)

WIPIC reserves the right to amend specifications in the light of continuing development.

KW 1-08

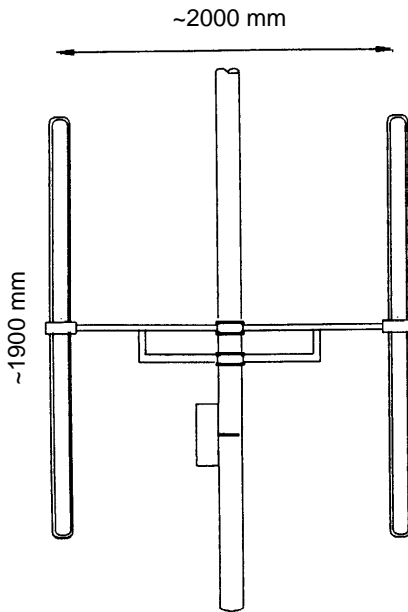

<b>TYPE NO.</b>	<b>WS 253 12 13 4: 68 - 82 MHz</b> <b>WS 253 12 13 5: 74 - 88 MHz</b> further frequencies on request, light execution
<b>POLARIZATION</b>	vertical
<b>IMPEDANCE</b>	50 Ω
<b>GAIN</b>	1.5 - 2.2 dB (ref. to λ/2 dipole)
<b>VSWR</b>	< 1.3, at the limits of the band < 1.5
<b>POWER</b>	max. 500 watts, higher power on request
<b>3 dB BEAMWIDTH</b>	horizontal, H-plane: 2x 69° vertical, E-plane: 78°
<b>TERMINATION</b>	in the junction box WAK 1 ending with N male other termination on request
<b>GROUNDING</b>	all metal parts are DC grounded
<b>MOUNTING</b>	<i>mast</i> ∅ <i>clamp</i> (see chapt. 10) 30 - 80 mm    WG 13 (standard) 50 - 104 mm   WG 14 (option) clamp for other mast-∅ on request
<b>MATERIAL</b>	aluminium, bolts of stainless steel, weather-resistant plastic
<b>WEIGHT</b>	5 kg
<b>WIND AREA</b>	0.2 m <sup>2</sup>
<b>WIND LOAD</b>	255 N 150 km/h 190 N 130 km/h

Horizontal Radiation Pattern H Plane

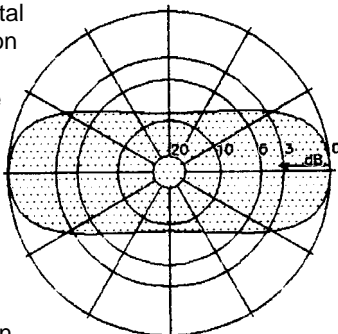

Vertical Radiation Pattern E Plane

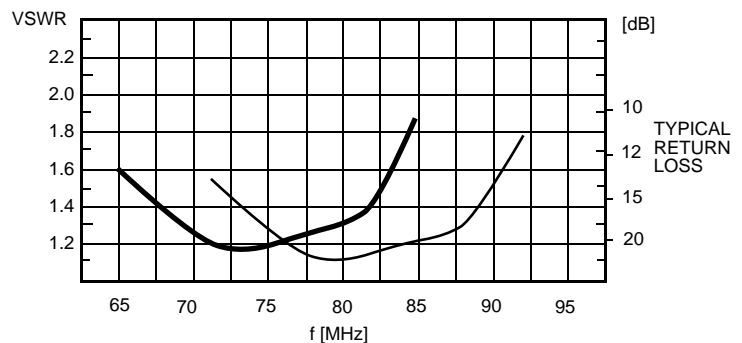
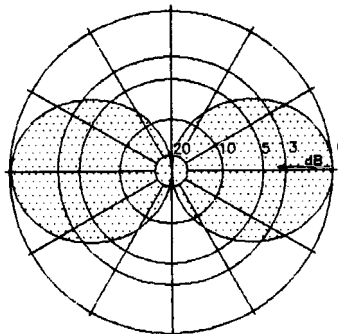

KW 1-08

WIPIC reserves the right to amend specifications in the light of continuing development.

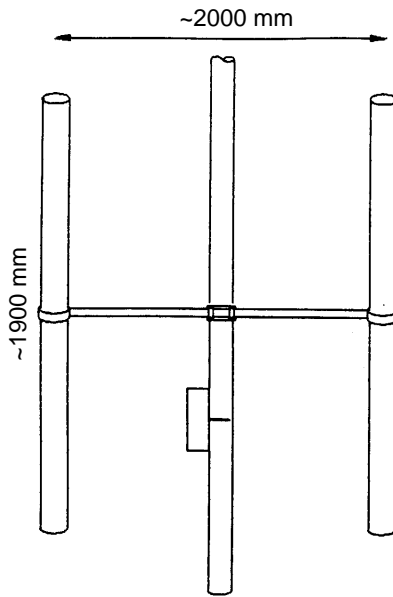

**TYPE NO.** WS 253 13 13 4: 68 - 82 MHz  
 WS 253 13 13 5: 74 - 88 MHz  
 further frequencies on request

**DESCRIPTION** heavy duty, with radom  
 The radom protects the antenna dipole against environmental influences, icing, and increases the lightning protection.

**POLARIZATION** vertical

**IMPEDANCE** 50 Ω

**GAIN** 1.5 - 2.2 dB (ref. to λ/2 dipole)

**VSWR** < 1.3, at the limits of the band < 1.5

**POWER** 500 watts, higher power on request

**3 dB BEAMWIDTH** horizontal, H-plane: 2x69°  
 vertical, E-plane: 70°

**TERMINATION** in the junction box WAK 1 ending with N male  
 other termination on request

**GROUNDING** all metal parts are DC grounded

**MOUNTING** mast ø clamp (see chapt. 10)  
 30 - 80 mm WG 17 (standard)  
 50 - 104 mm WG 18 (option)  
 clamp for other mast-ø on request

**MATERIAL** aluminium, bolts of stainless steel, radom of UV-stabilized polyethylene

**WEIGHT** 11 kg  
**WIND AREA** 0.38 m<sup>2</sup>  
**WIND LOAD** 485 N 150 km/h  
 365 N 130 km/h

Horizontal Radiation Pattern H Plane

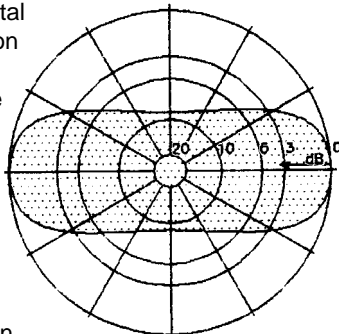

Vertical Radiation Pattern E Plane

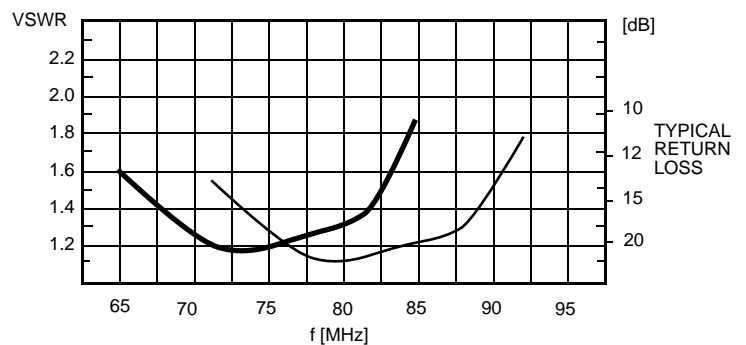
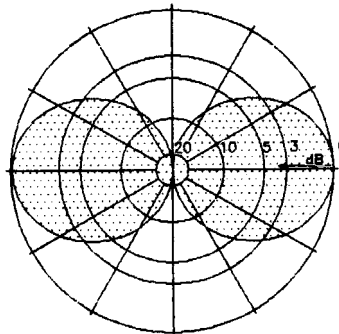

KW 1-09

WIPIC reserves the right to amend specifications in the light of continuing development.

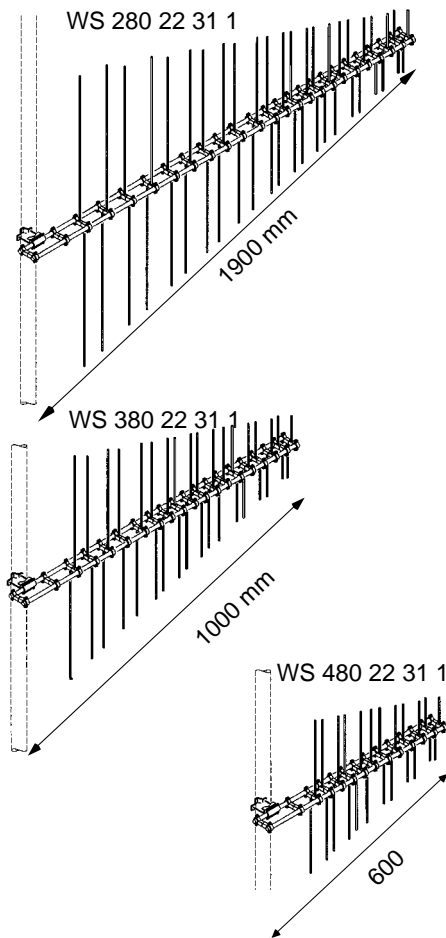

<b>TYPE NO.</b>	<b>Type</b>	<b>MHz</b>	<b>L</b>
	WS 280 22 31 1	87.5 - 1000	1900
	WS A80 22 31 1	108 - 1000	1500
	WS 380 22 31 1	174 - 1000	1000
	WS 480 22 31 1	470 - 1000	600
	other bands on request		
<b>POLARIZATION</b>	vertikal or horizontal on request		
<b>IMPEDANCE</b>	50 or 75 Ω		
<b>GAIN</b>	5-6dB ref. λ/2 Dipol 7-8 dBi F/B 20 - 25 dB		
<b>VSWR</b>	≤ 2.5 preferred < 1.5		
<b>POWER</b>	300 - 1000 watts		
<b>3 dB BEAMWIDTH</b>	E-plane:	60 - 70°	
	H-plane:	110 - 130°	
<b>TERMINATION</b>	2 m cable RG 213/U or RG 11 ending with N male other termination on request		
<b>GROUNDING</b>	all metal parts are DC grounded		
<b>MOUNTING</b>	mast-∅	clamp	
	30 - 80 mm	WG 11 (standard)	
	50 - 104 mm	WG 12 (option)	
	clamp for other mast-∅ on request		
<b>MATERIAL</b>	aluminium, bolts of stainless steel, weather-resistant plastics		
<b>WEIGHT</b>	280 ..	380 ..	480 ..
<b>WIND AREA</b>	3.9 kg	2.3 kg	1.4 kg
<b>WIND LOAD</b>	0.21 m <sup>2</sup>	0.093 m <sup>2</sup>	0.052 m <sup>2</sup>
	270 N	120 N	66 N at 150 km/h
	200 N	90 N	50 N at 130 km/h

WS 280 22 31 1

