

ANTENNAS for TV, FM and AM

50Ω 75Ω

Content	Band	Frequency	Page
General Informations			2
FBE and FWS 10...	Band 1	TV 47 - 68 MHz	5
UBE and FWS 20...	Band 2	FM 87.5 - 108 MHz	9
FBE and FWS 3....	Band 3	TV 174 - 230 MHz	21
FBE and FWS 4....	Band 4/5	TV 470 - 862 MHz	27
Ship antennas	Band 1 - 5	47 - 862 MHz	39

FBE and UBE type

- | | | |
|----------|---|--|
| 1 | .BE .. -0 . | no longer available |
| 2 | .BE .. -1. | robust construction, balun with cable, 75 Ω
termination: 10 m cable RG 59 (ø 6.5 mm), without connector |
| 3 | .BE .. -2. | robust construction, balun with cable, 75 Ω
termination: 10 m cable RG 11 (ø 10.5 mm), without connector |
| 4 | FWS type | FWS-antennas are tuned to the specified channel or channel group
balun with cable, especially designed for collective antenna systems

IMPEDANCE 50 or 75 Ω nominal
VSWR 50 Ω <1.3 (or <1.5 for channel groups)
75 Ω <1.5
TERMINATION 2m cable with ø 10.5 mm
50 Ω RG 213/U ending with N male
75 Ω RG 11 ending with N male
POWER Band II: 200 Watts
(only for 50 Ω impedance) |
| 5 | FWS ... 02 ..
without radome | robust construction (similar FBE ...-2), electrical details as specified under 4 |
| 6 | FWS ... 03 ..
with radome | heavy duty, with radome
The radome protects the antenna dipole from environmental influences, icing, and increases the lightning protection. Other details specified under 4 . |

MATERIAL aluminium, screws of stainless steel, radome of uv-stabilized polyethylene, weather resistant plastics

MOUNTING clamp for mast ø 30 - 80 mm (standard)
clamp for mast ø 50 - 104 mm (option)

ORDER Please give the following details when ordering:
type, channel, impedance, polarization
for ex.: - FWS 306 02, ch 12, 50 Ω, horizontal polarization
- FBE 311-112, ch 12, 75 Ω, vertical polarization

Technical details of WIPIC antennas:

- robust construction
- different types for various weather conditions
- no perforation of the antenna boom

illustration: four element band III yagi antenna, dipole without and with radome

Type without radome

FBE 304-0/1/2 (VSWR not individually measured)

FWS 304 02 (VSWR individually measured)

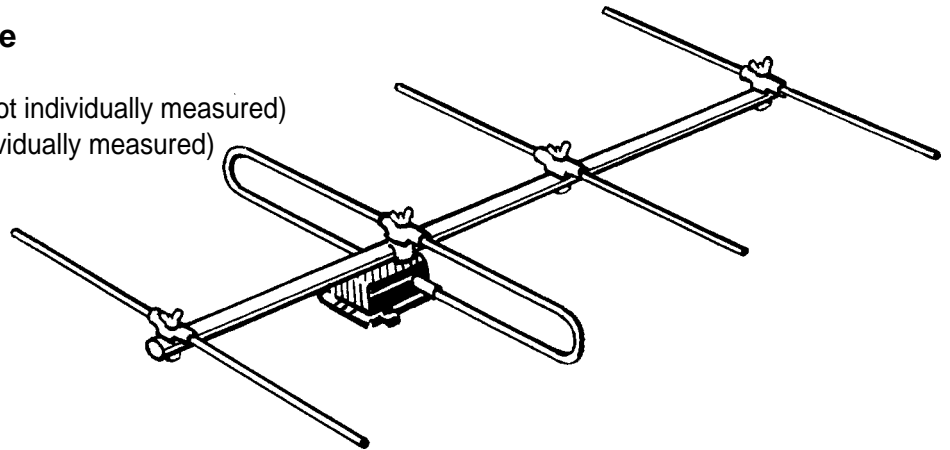

Wipic antennas without radome are solidly built for long maintenance free operation. All parts replaceable.

Type with radome

FWS 304 03 (VSWR individually measured)

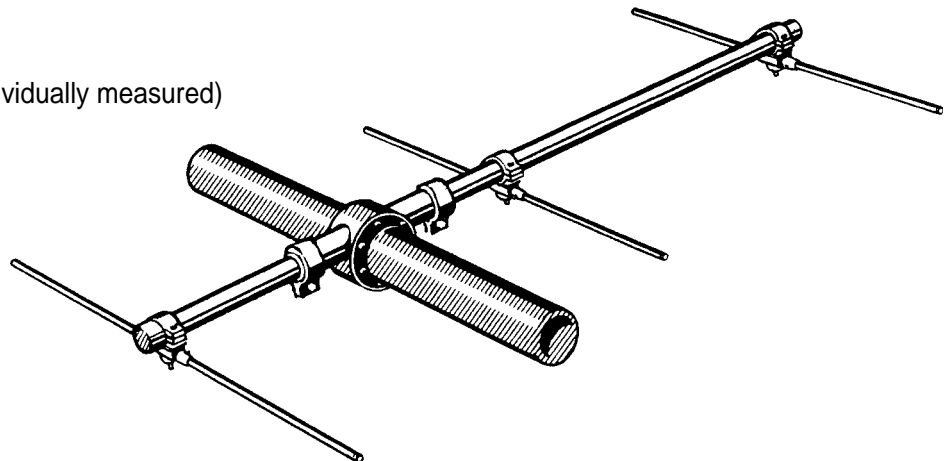

WIPIC antennas with radome are solidly built for long maintenance free operation under severe weather condition, heavy duty
The radome protects the antenna dipole from environmental influences, icing, and increases the lightning protection.

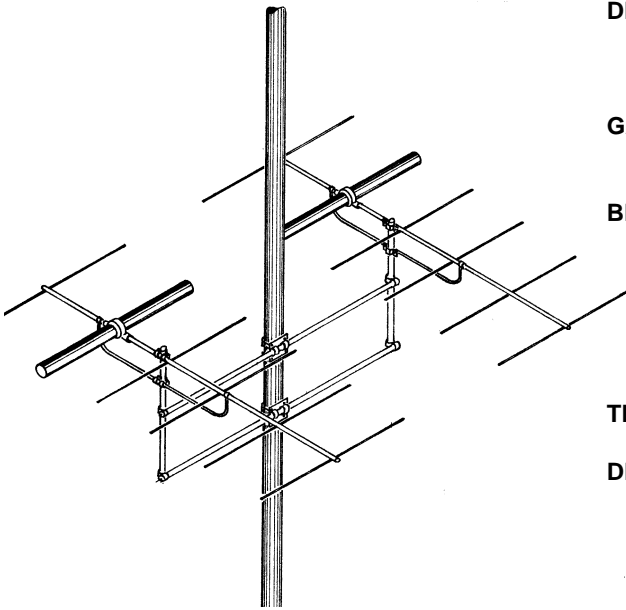

FM twin antenna consisting of two FWS 206 03 distance 2800 mm

DESCRIPTION Coupling of identical FWS antennas into one group
some examples are illustrated below

GAIN twin and two-level +3 dB
quadro +5 dB

BEAM WIDTH Twin antennas reduce the horizontal beam width
Two-level antennas reduce the vertical beam width
Quadro antennas reduce the horizontal and vertical beam width

TERMINATION in the junction box ending with N male

DELIVERY antennas
junction box WAK 1
brackets with clamps for mast \varnothing 30 - 80 mm (standard) or 50 - 104 mm (option)
(see chapter: Mounting Clamps)

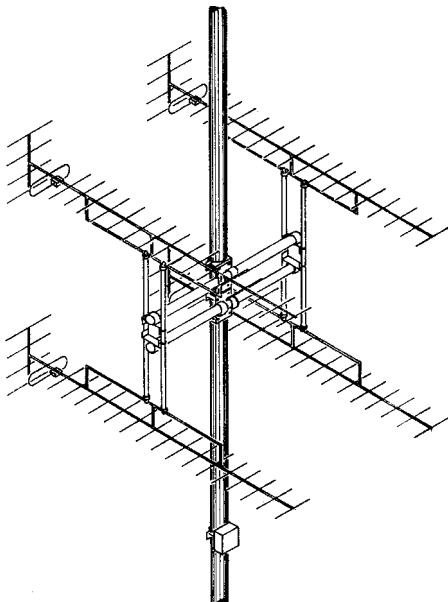

quadro antenna consisting of four FWS 421 02 horizontal and vertical distance ~800 mm

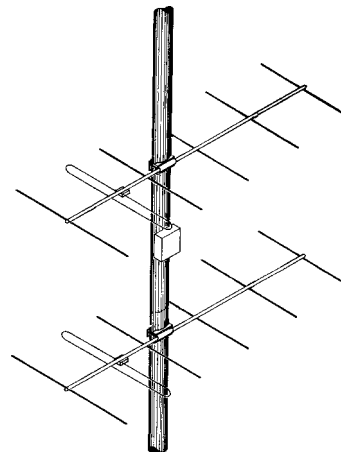

two-level antenna consisting of two FWS 306 02 distance 1800 mm

TV-ANTENNAS BAND I (48 - 68 MHz)
 For channel 2, 3 or 4
 horizontal polarization

FBE 102 -.
FBE 103 -.
FBE 104 -.
FBE 106 -.

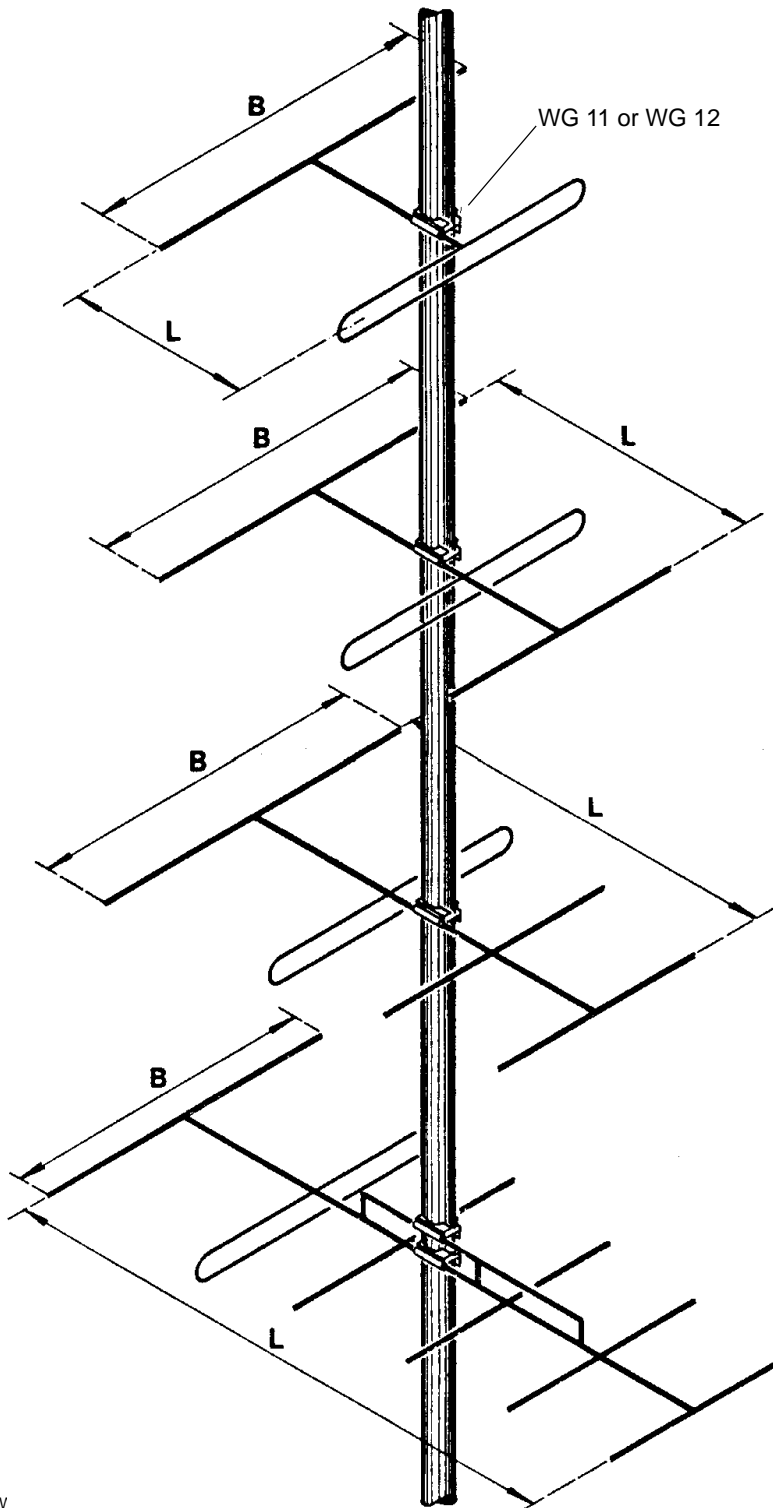

2-ELEMENT YAGI ANTENNA

type no. FBE 102-0
 FBE 102-1
 FBE 102-2
gain 3.5 dB (ref. $\lambda/2$ dipole)
F/B 9 dB

3 dB beam width horizontal, E plane 80°
 vertical, H plane 135°

3-ELEMENT YAGI ANTENNA

type no. FBE 103-0
 FBE 103-1
 FBE 103-2
gain 5 dB (ref. $\lambda/2$ dipole)
F/B 14 dB

3 dB beam width horizontal, E plane 80°
 vertical, H plane 115°

4-ELEMENT YAGI ANTENNA

type no. FBE 104-0
 FBE 104-1
 FBE 104-2
gain 6 dB (ref. $\lambda/2$ dipole)
F/B 16 dB

3 dB beam width horizontal, E plane 60°
 vertical, H plane 100°

6-ELEMENT YAGI ANTENNA

type no. FBE 106-0
 FBE 106-1
 FBE 106-2
gain 8 dB (ref. $\lambda/2$ dipole)
F/B 20 dB

3 dB beam width horizontal, E plane 80°
 vertical, H plane 115°

KV

amend specifications in the light of continuing development.

- FBE 10.-0 no longer available

- FBE 10.-1 balun with cable (for increased lightning protection)
 termination: 10 m RG 59 (ø 6.5 mm), without connector
 impedance: 75 Ω

- FBE 10.-2 similar FBE ...-1, but terminated with 10 m RG 11 (ø 10 mm)

	channel	weight ¹⁾ [kg]	wind area[m ²]	wind load ²⁾ [N]	length L [m]	wide B [m]
FBE 102.-	2	1.7	0.094	53	1.1	3.3
	3	1.6	0.082	46	1.0	2.9
	4	1.6	0.073	41	0.9	2.6
FBE 103.-	2	2.1	0.118	67	2.1	3.3
	3	1.9	0.103	59	1.9	2.9
	4	1.8	0.091	52	1.7	2.6
FBE 104.-	2	2.3	0.142	80	2.5	3.3
	3	2.2	0.114	65	2.5	2.9
	4	2.1	0.100	57	2.2	2.6
FBE 106.-	2	4.2	0.195	110	3.8	3.3
	3	3.9	0.165	94	3.3	2.9
	4	3.6	0.146	83	2.9	2.6

1) **weight** with clamp, without cable
 weight of the cable: ø 6.5 mm : 0.6 kg/10m
 ø 10 mm : 1.6 kg/10m

2) **windload:** at 100 km/h
 at 130 km/h: multiply windload at 100 km/h by 1.7
 at 150 km/h: multiply windload at 100 km/h by 2.25

mounting: with clamp WG 11 for mast-ø 30-80 mm (standard)
 with clamp WG 12 for mast-ø 50-104 mm (option)
 connection box below the boom
 pay attention to the label DOWN



TV-ANTENNAS BAND I (48 ... 68 MHz)

For channel 2, 3 or 4

horizontal polarization

type with radome

FWS 103 03

FWS 104 03

FWS 106 03

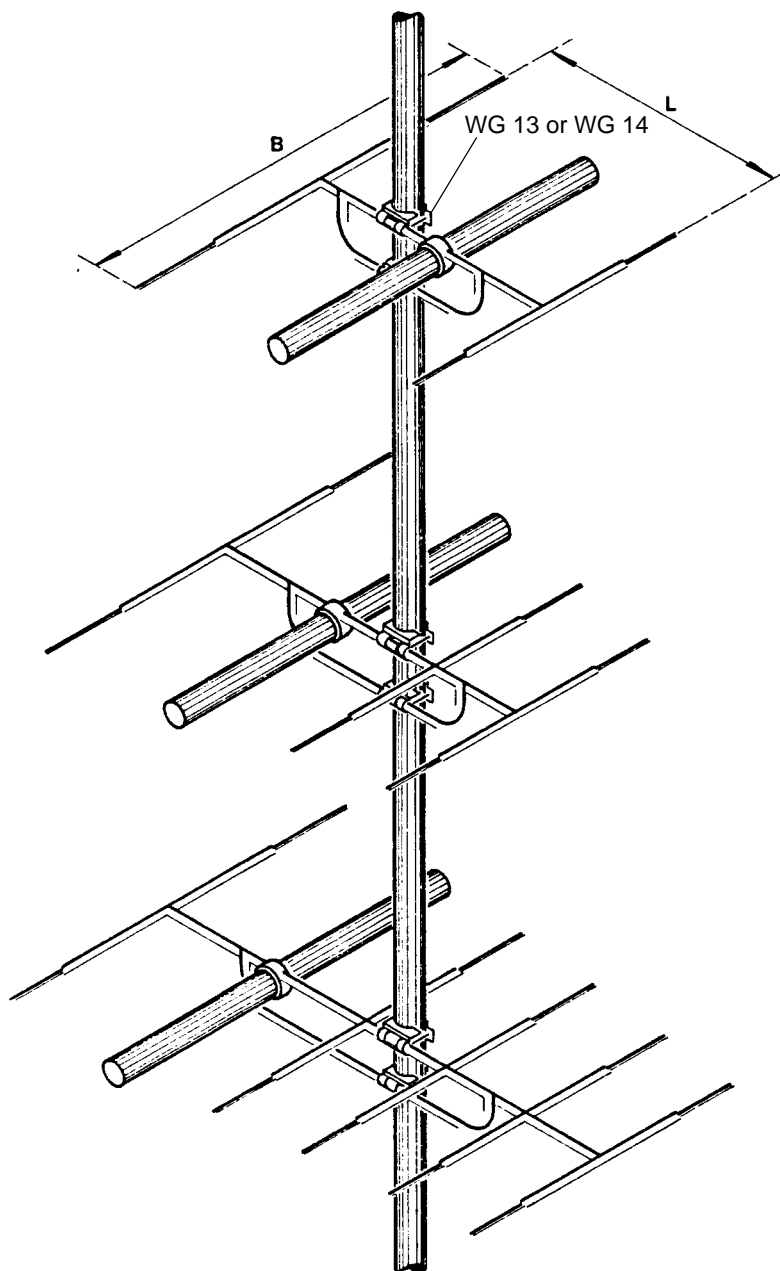

2-ELEMENT YAGI ANTENNA

type no. **FWS 103 03**

gain 5 dB ref. $\lambda/2$ dipole

F/B 14 dB

3 dB beam width horizontal, E plane 70°
vertical, H plane 115°

4-ELEMENT YAGI ANTENNA

type no. **FWS 104 03**

gain 6 dB ref. $\lambda/2$ dipole

F/B 16 dB

3 dB beam width horizontal, E plane 60°
vertical, H plane 100°

6-ELEMENT YAGI ANTENNA

type no. **FWS 106 03**

gain 8 dB ref. $\lambda/2$ dipole

F/B 20 dB

3 dB beam width horizontal, E plane 50°
vertical, H plane 80°

Description	heavy duty, dipole with radome The radome protects the antenna dipole from environmental influences, icing, and increases the lightning protection. SWR individually measured especially suited for MATV
Polarization	horizontal
Frequency	tuned to channel 2, 3 or 4 in the band I
Impedance	50 Ω or 75 Ω
VSWR	< 1.2 < 1.5 for the whole channel
Termination	50Ω: 2m cable RG 213/U ending with N male 75Ω: 2m cable RG 11/U ending with N male
Material	aluminium, screws of stainless steel, radome of UV-stabilized polyethylene
Grounding	all metal parts are DC grounded
Mounting	<i>mast-∅</i> <i>clamp</i> 30 - 80 mm 2x WG 13 (standard) 50 -104 mm 2x WG 14 (option) pay attention to the label DOWN
max. wind velocity	200 km/h

Type	channel CICR	weight kg	wind area m ²	wind load [N]		length L [m]	wide B [m]
				130 km/h	150		
FWS 103 03	2	9.6	0.324	301	420	2.1	3.3
	3	9.0	0.290	280	376	1.9	2.9
	4	8.5	0.264	253	342	1.7	2.6
FWS 104 03	2	10.8	0.373	357	483	2.8	3.3
	3	10.3	0.337	323	436	2.5	2.9
	4	9.7	0.307	294	398	2.2	2.6
FWS 106 03	2	13.7	0.482	462	624	3.8	3.3
	3	12.5	0.429	411	556	3.3	2.9
	4	11.6	0.385	370	491	2.9	2.6

FM-ANTENNAS
87.5 - 108 MHz
 horizontal polarization

UBE 20. -.

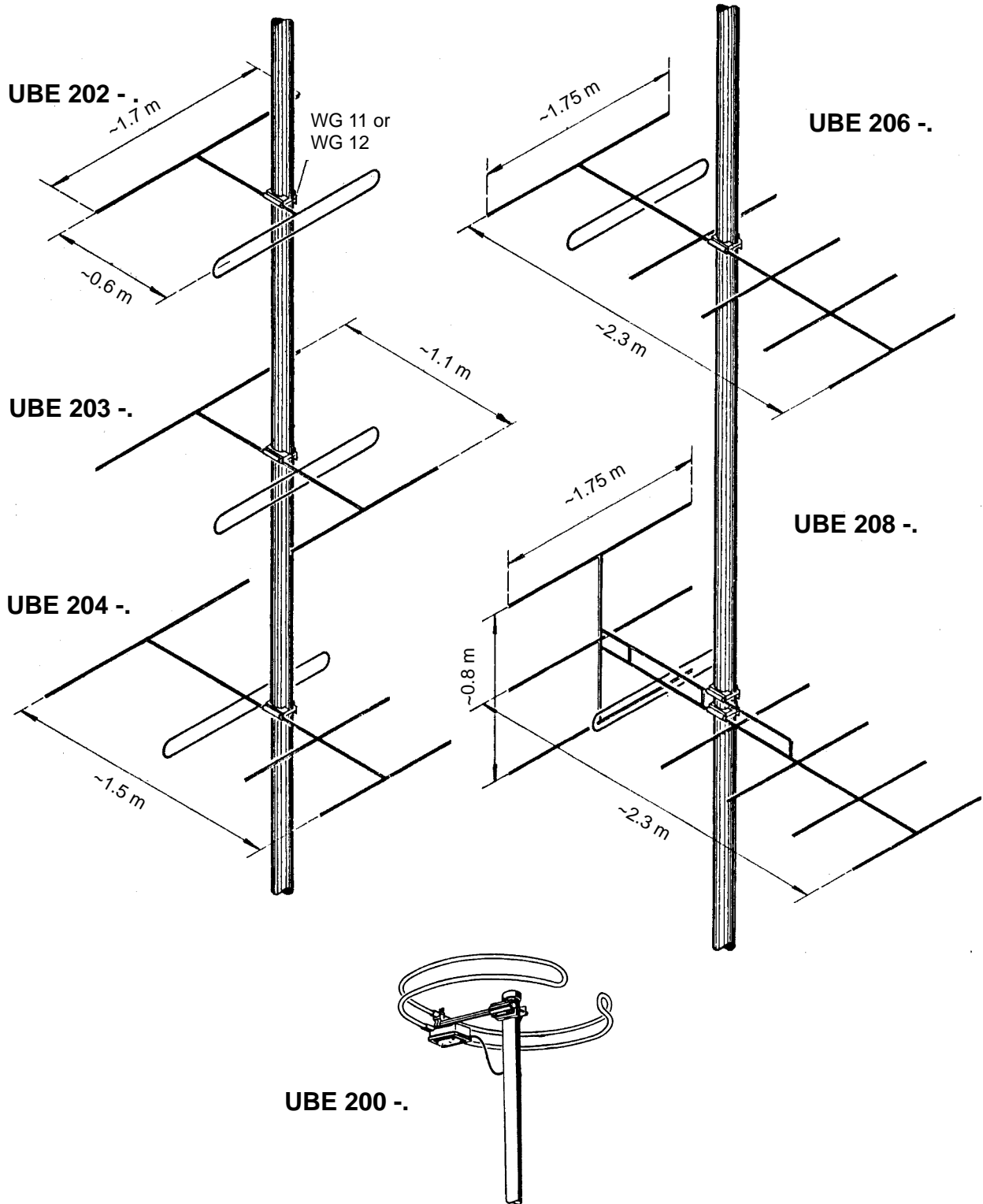

TYPE	UBE 20. -0 : no longer available		
	UBE 20. -1 : balun with cable (for increased lightning protection) termination 10 m RG 59 (ø 6.5 mm), without connector		
	UBE 20. -2 : similar UBE 20. -1 but terminated with 10 m RG 11 (ø 10 mm)		
POLARIZATION	horizontal		
FREQUENCY	87.5 - 108 MHz		
IMPEDANCE	75 Ω		
MATERIAL	aluminium, screws of stainless steel, weather-proof plastics		
GROUNDING	all metal parts are DC grounded		
MOUNTING	<i>mast-ø</i>	<i>mounting clamp</i>	
	30 - 80 mm	WG 11 (standard)	2 clamps for UBE 208..
	50 -104 mm	WG 12 (option)	2 clamps for UBE 208..
	104-138 mm	special order	
	> 138	special brackets	
	pay attention to the label DOWN		

TYPE	UBE 202..	UBE 203..	UBE 204..	UBE 206..	UBE 208..	UBE 200..
GAIN (ref. to λ/2 dipole)	3.5	5	6.5	8	9	-2
F/B in dB >	9	14	16	20	25	
3 dB BEAMWIDTH						
horizontal, E plane	80°	70°	60°	50°	45°	360°
vertical, H plane	135°	115°	90°	72°	62°	
WEIGHT [kg]	1.3	1.6	1.8	2.5	4.0	1.5
WIND AREA [m²]	0.053	0.066	0.080	0.105	0.159	0.05
WIND LOAD [N]						
150 km/h	67	84	102	134	203	63
130 km/h	51	64	77	100	153	47

wipic -Antennas

FM-ANTENNAS
87.5 - 108 MHz
vertical polarization

UBE 202 -.12

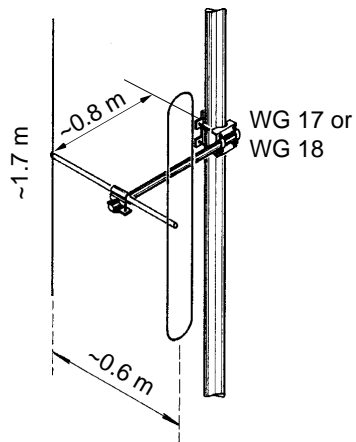

UBE 206 -.12

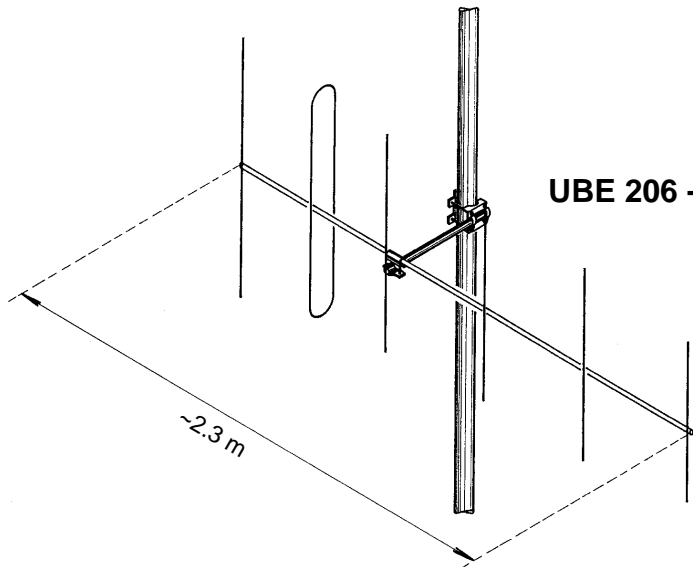

UBE 203 -.12

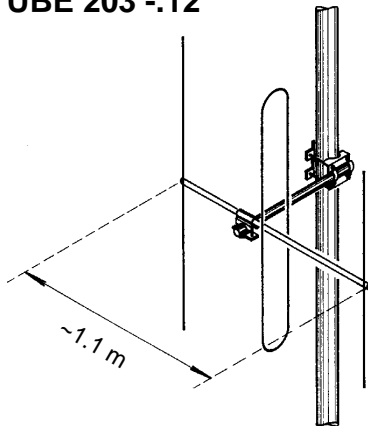

UBE 208 -.12

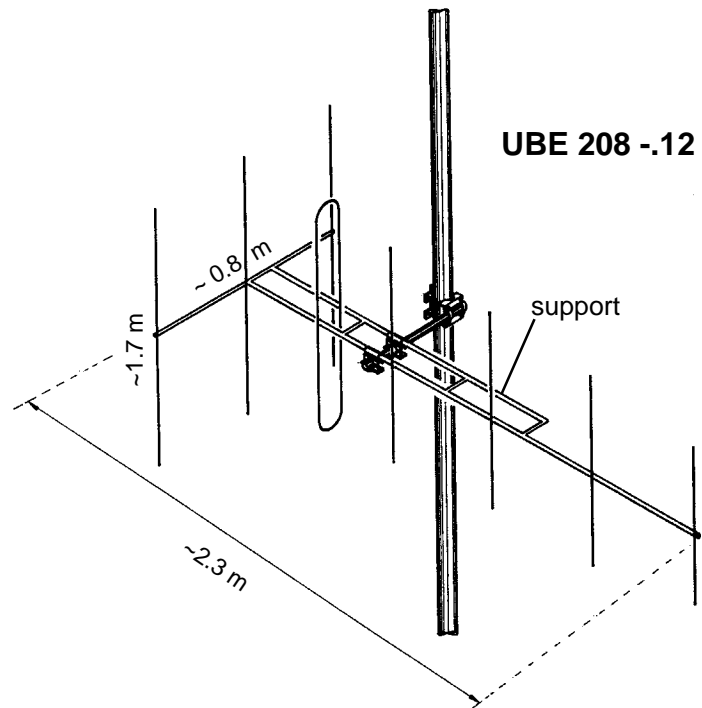

UBE 204 -.12

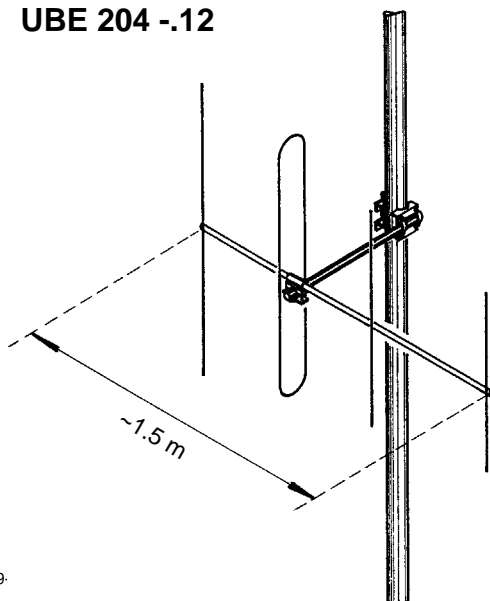

KW 9.

WIPIC reserves the right to amend specifications in the light of continuing development.

TYPE	UBE 20. -012 : no longer available UBE 20. -112 : balun with cable (for increased lightning protection) termination 10 m RG 59 (ø 6.5 mm), without connector UBE 20. -212 : similar UBE 20. -112 but terminated with 10 m RG 11 (ø 10 mm)										
POLARIZATION	vertical										
FREQUENCY	87.5 - 108 MHz										
IMPEDANCE	75 Ω										
MATERIAL	aluminium, screws of stainless steel, weather-proof plastics										
GROUNDING	all metal parts are DC grounded										
MOUNTING	<table> <tr> <td><i>mast-ø</i></td> <td><i>mounting clamp</i></td> </tr> <tr> <td>30 - 80 mm</td> <td>WG 17 (standard)</td> </tr> <tr> <td>50 -104 mm</td> <td>WG 18 (option)</td> </tr> <tr> <td>104-138 mm</td> <td>special order</td> </tr> <tr> <td colspan="2">pay attention to the label DOWN</td> </tr> </table>	<i>mast-ø</i>	<i>mounting clamp</i>	30 - 80 mm	WG 17 (standard)	50 -104 mm	WG 18 (option)	104-138 mm	special order	pay attention to the label DOWN	
<i>mast-ø</i>	<i>mounting clamp</i>										
30 - 80 mm	WG 17 (standard)										
50 -104 mm	WG 18 (option)										
104-138 mm	special order										
pay attention to the label DOWN											

TYPE	<i>UBE 202..</i>	<i>UBE 203..</i>	<i>UBE 204..</i>	<i>UBE 206..</i>	<i>UBE 208..</i>
GAIN (ref. to $\lambda/2$ dipole)	3.5	5	6.5	8	9
F/B in dB >	9	14	16	20	25
3 dB BEAMWIDTH					
horizontal, E plane	80°	70°	60°	50°	45°
vertical, H plane	135°	115°	90°	72°	62°
WEIGHT [kg]	1.3	2.6	2.8	3.5	5.0
WIND AREA [m²]	0.08	0.093	0.11	0.132	0.186
WIND LOAD [N]					
150 km/h	102	118	136	168	237
130 km/h	76	89	102	126	178

FM-ANTENNAS 87.5 - 108 MHz
horizontal polarization
type without radom

FWS 2.. 02

FWS 204 02

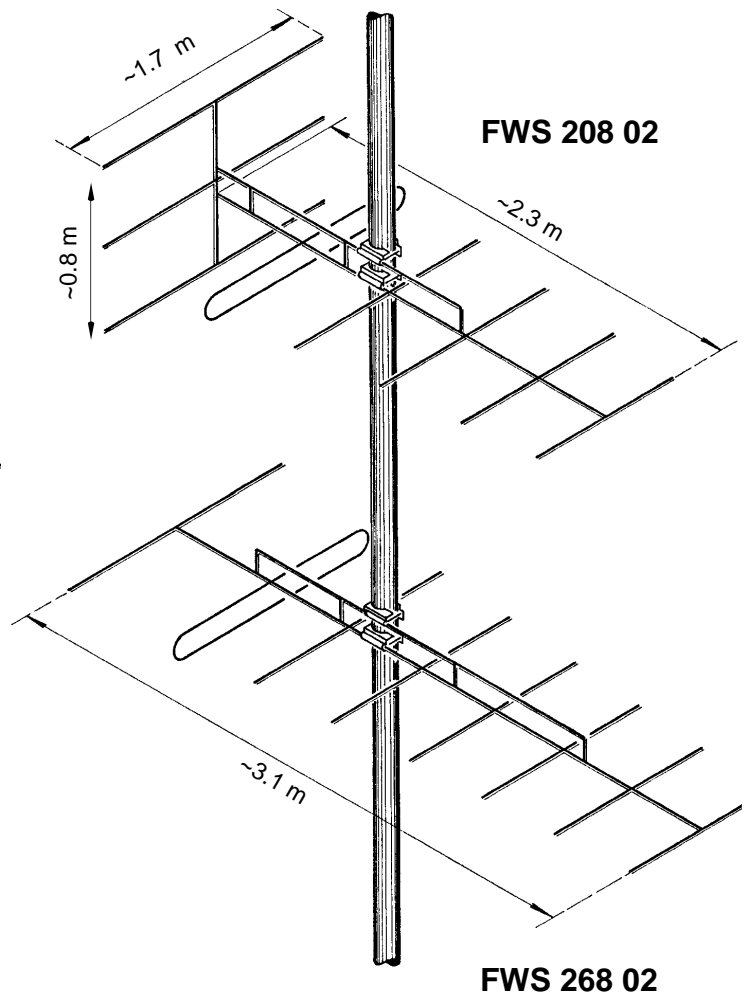
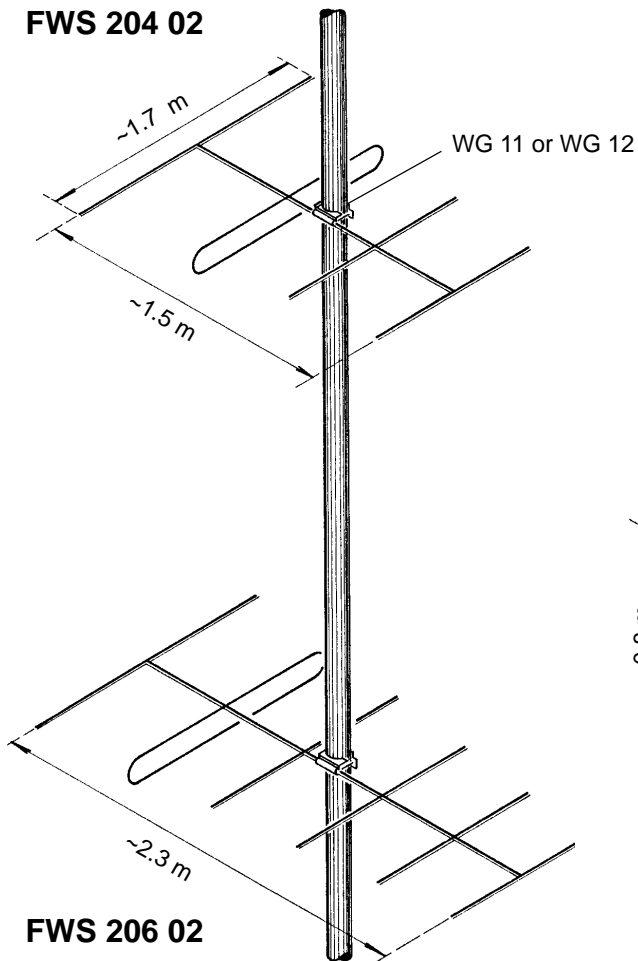

FWS 208 02

FWS 206 02

FWS 268 02

Description	robust construction SWR individually measured especially suited for MATV For exposed location (icing, environment, lightning) we recommend the type with radome (FWS 2.. 03).
Polarization	horizontal
Frequency	tuned to the specified frequency or for the FM band 87.5 - 108 MHz
Impedance	50 Ω or 75 Ω
VSWR	< 1.2 on tuned frequency < 1.4, at the limits of the band < 1.5
Termination	50Ω: 2m cable RG 213/U ending with N male 75Ω: 2m cable RG 11/U ending with N male
Material	aluminium, screws of stainless steel, weather-proof plastics
Grounding	all metal parts are DC grounded
Mounting	<i>mast-ø</i> <i>clamp</i> 30 - 80 mm WG 11 (standard) 2x for FWS 2.8.. 50 - 104 mm WG 12 (option) 2x for FWS 2.8.. pay attention to the label DOWN
max. wind velocity	160 km/h

Type	FWS 204 02	FWS 206 02	FWS 208 02	FWS 268 02
Gain [dB] ref. λ/2 dipole	6.5	8	9	9
F/B [dB]	16	20	25	20
3 dB beam width horizontal, E plane	60°	50°	45	45°
vertical, H plane	90°	72°	62°	62°
Weight [kg]	2.1	2.8	4.3	4.5
Wind area [m²]	0.080	0.105	0.159	0.143
Wind load [N]				
150 km/h	104	136	206	185
130 km/h	76	100	152	137

wipic -Antennas

FM-ANTENNAS 87.5 - 108 MHz
vertical polarization
type without radom

FWS 20. 02 12

FWS 200 84 1

mounting to 30-66 mm \varnothing mast
cable running inside or outside the
mast
termination ~1m cable with N male

FWS 204 02 12

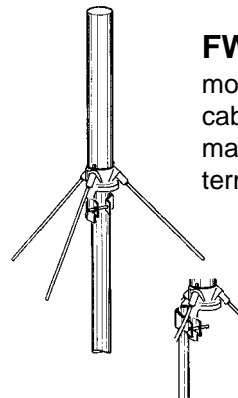
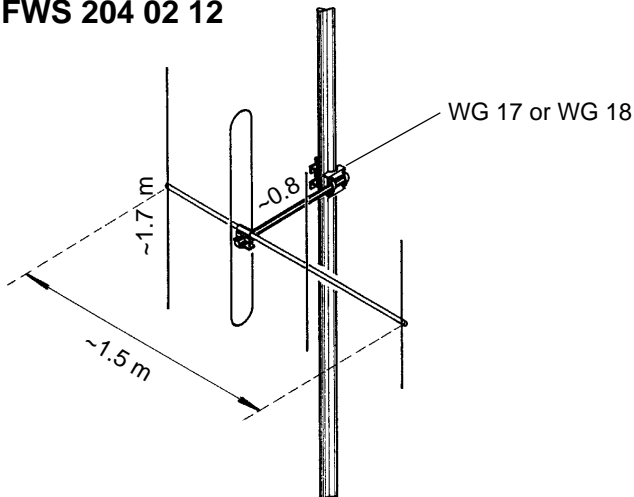

FWS 206 02 12

FWS 208 02 12

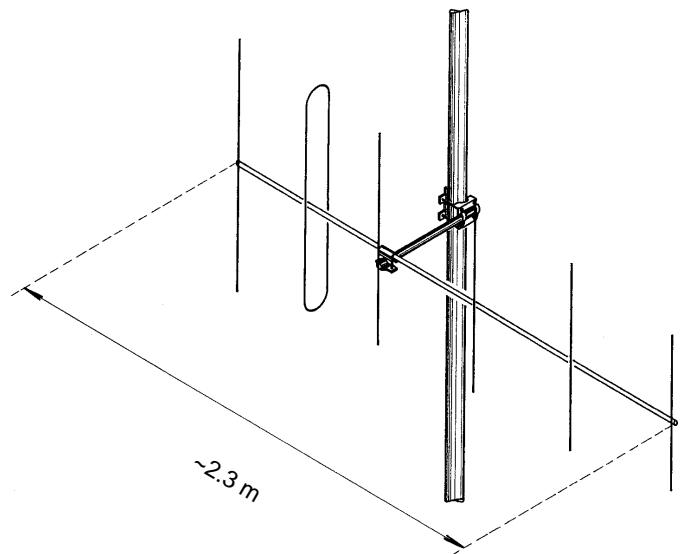
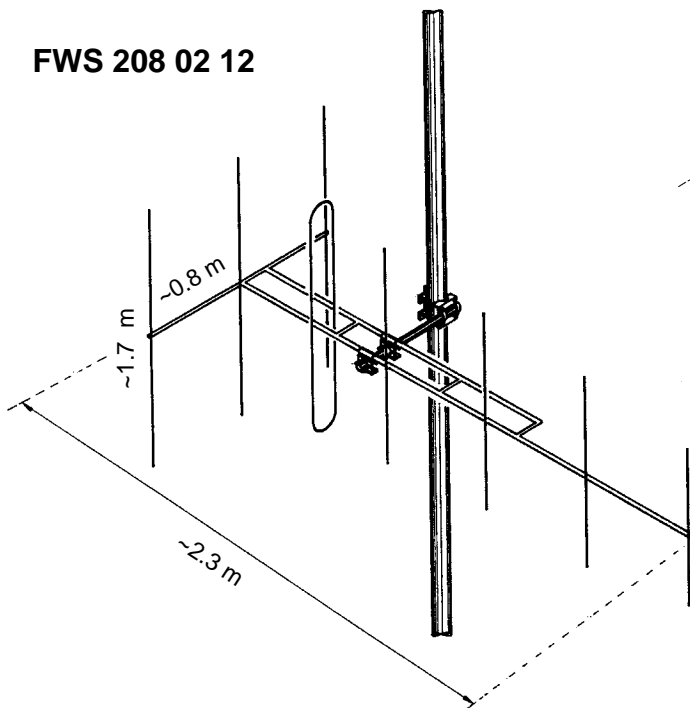

Description	robust construction SWR individually measured especially suited for MATV For special cases (icing, environment, lightning) we recommend the type with radome (FWS 2.. 03).
Polarization	vertical
Frequency	tuned to the specified frequency or for the FM band 87.5 - 108 MHz
Impedance	50 Ω oder 75 Ω
VSWR	< 1.2 on tuned frequency < 1.4, at the limits of the band < 1.5
Termination	50Ω: 2m cable RG 213/U ending with N male 75Ω: 2m cable RG 11/U ending with N male
Material	aluminium, screws of stainless steel, weather-proof plastics
Grounding	all metal parts are DC grounded
Mounting	<i>mast-∅</i> <i>clamp</i> 30 - 80 mm WG 17 (standard) 50 -104 mm WG 18 (option) pay attention to the label DOWN
max. wind velocity	160 km/h

Type	FWS 200 84 1	FWS 204 02 12	FWS 206 02 12	FWS 208 02 12
Gain [dB] ref. λ/2 dipole	0	6.5	8	9
F/B [dB]	--	16	20	25
3 dB beam width horizontal, E plane	360°	60°	50°	45°
vertical, H plane	78°	90°	72°	62°
Weight [kg]	1.8	2.1	2.8	4.3
Wind area [m²]	0.056	0.080	0.105	0.159
Wind load [N]				
150 km/h	72	104	136	206
130 km/h	54	76	100	152

FM ANTENNAS 87.5 - 108 MHz
type with radome

FWS 204 03
FWS 206 03
FWS 208 03

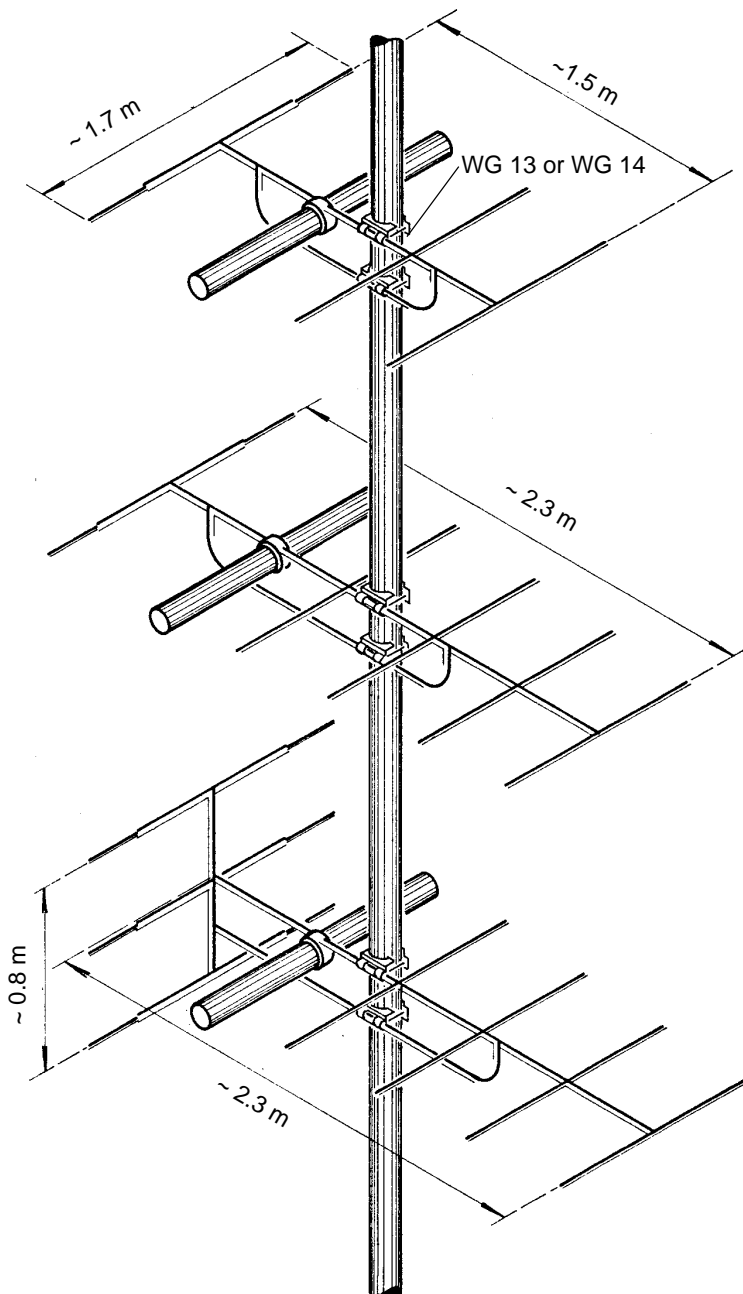

4-ELEMENT YAGI ANTENNA

type no. **FWS 204 03**
gain 6.5 dB ref. $\lambda/2$ dipole
F/B 16 dB

3 dB beam width horizontal, E plane 60°
vertical, H plane 90°

6-ELEMENT YAGI ANTENNA

type no. **FWS 206 03**
gain 8 dB ref. $\lambda/2$ dipole
F/B 20 dB

3 dB beam width horizontal, E plane 50°
vertical, H plane 72°

8-ELEMENT YAGI ANTENNA

type no. **FWS 208 03**
gain 9 dB ref. $\lambda/2$ dipole
F/B 25 dB

3 dB beam width horizontal, E plane 45°
vertical, H plane 62°

Description	heavy duty, dipole with radome The radome protects the antenna dipole from environmental influences, icing, and increases the lightning protection. SWR individually measured especially suited for MATV
Polarization	horizontal
Frequency	tuned to specified frequency or for the FM band 87.5-108 MHz
Impedance	50 Ω oder 75 Ω
VSWR	< 1.2 on tuned frequency < 1.5 for the whole band
Termination	50Ω: 2m cable RG 213/U ending with N male 75Ω: 2m cable RG 11/U ending with N male
Material	aluminium, screws of stainless steel, radome of UV-stabilized polyethylene
Grounding	all metal parts are DC grounded
Mounting	<i>mast-ø</i> <i>clamp</i> 30 - 80 mm 2x WG 13 (standard) 50 - 104 mm 2x WG 14 (option) pay attention to the label DOWN
max. wind velocity	200 km/h

Type No.	<i>FWS 204 03</i>	<i>FWS 206 03</i>	<i>FWS 208 03</i>
Weight [kg]	7.2	8.9	10.6
Wind area [m²]	0.22	0.278	0.362
Wind load [N]			
150 km/h	286	360	469
130 km/h	212	266	374

wipic -Antennas

FM ANTENNAS 87.5 - 108 MHz
 type with radome
 vertical polarisation

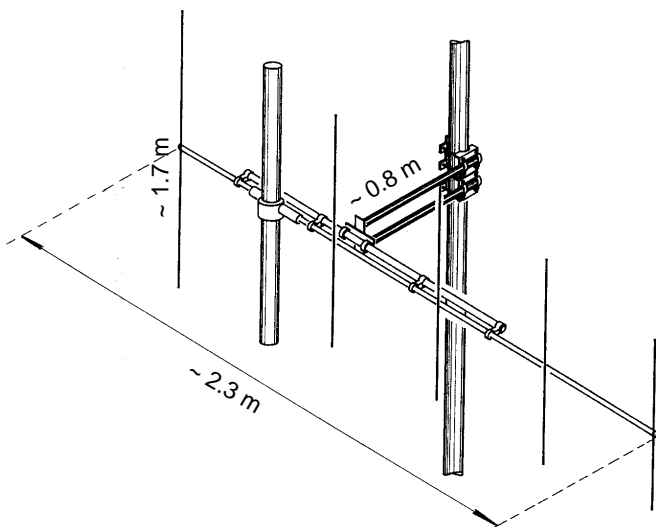
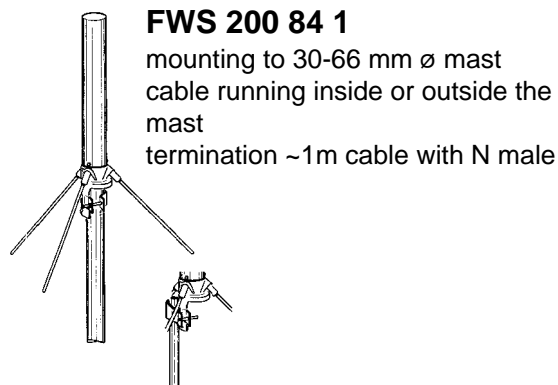
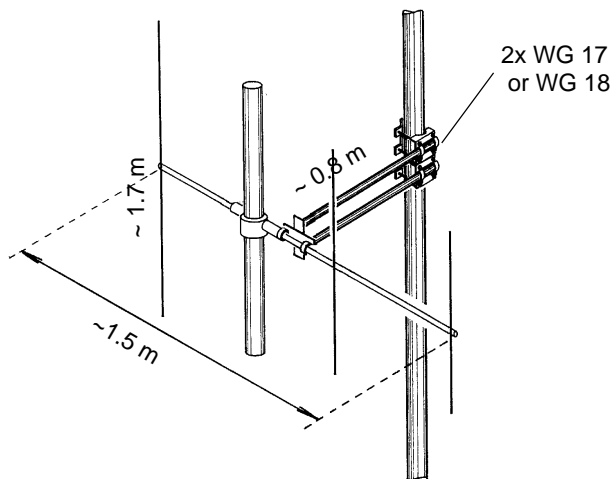

4-ELEMENT YAGI ANTENNA
 type no. **FWS 204 03 12**
 gain 6.5 dB ref. $\lambda/2$ dipole
 F/B 16 dB

3 dB beam width horizontal, H plane 90°
 vertical, E plane 60°

6-ELEMENT YAGI ANTENNA
 type no. **FWS 206 03 12**
 gain 8 dB ref. $\lambda/2$ dipole
 F/B 20 dB

3 dB beam width horizontal, H plane 72°
 vertical, E plane 50°

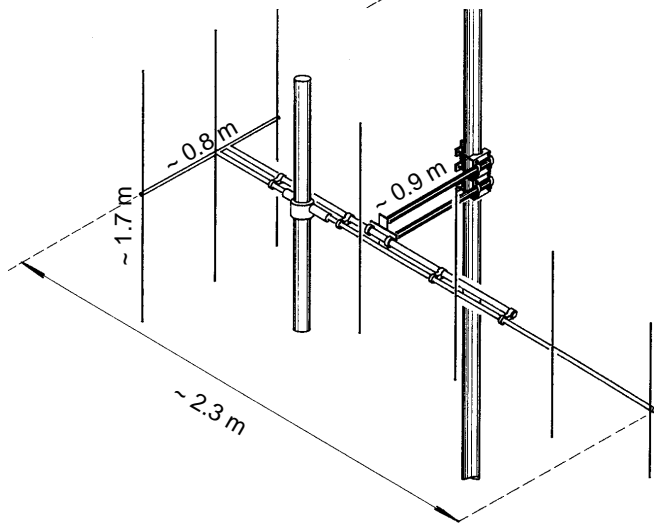

ELEMENT YAGI ANTENNA
 type no. **FWS 208 03**
 gain 9 dB ref. $\lambda/2$ dipole
 F/B 25 dB

3 dB beam width horizontal, H plane 62°
 vertical, E plane 45°

Description	heavy duty, dipole with radome The radome protects the antenna dipole from environmental influences, icing, and increases the lightning protection. VSWR individually measured especially designed for collective antenna systems
Polarization	vertical
Frequency	tuned to specified frequency or for the FM band 87.5-108 MHz
Impedance	50 Ω oder 75 Ω
VSWR	< 1.2 on tuned frequency < 1.3 at the limit of the band <1.5
Termination	50 Ω: 2m cable RG 213/U ending with N male 75 Ω: 2m cable RG 11/U ending with N male
Material	aluminium, screws of stainless steel, radome of UV-stabilized polyethylene
Grounding	all metal parts are DC grounded
Mounting	<i>mast-ø</i> <i>clamp</i> 30 - 80 mm 2x WG 17 (standard) 50 -104 mm 2x WG 18 (option) pay attention to the label DOWN
Max. wind velocity	200 km/h

Type No.	FWS 200 84 1	FWS 204 03 12	FWS 206 03 12	FWS 208 03 12
Weight [kg]	0	7.2	8.9	10.6
Wind area [m²]	0.056	0.28	0.34	0.422
Wind load [N]				
150 km/h	72	357	434	540
130 km/h	54	268	326	404

TV-ANTENNAS BAND III

For a channel group in the band III (175 - 230 MHz)
channel 5 12
horizontal polarization

FBE 304 -.
FBE 306 -.
FBE 308 -.
FBE 311 -.

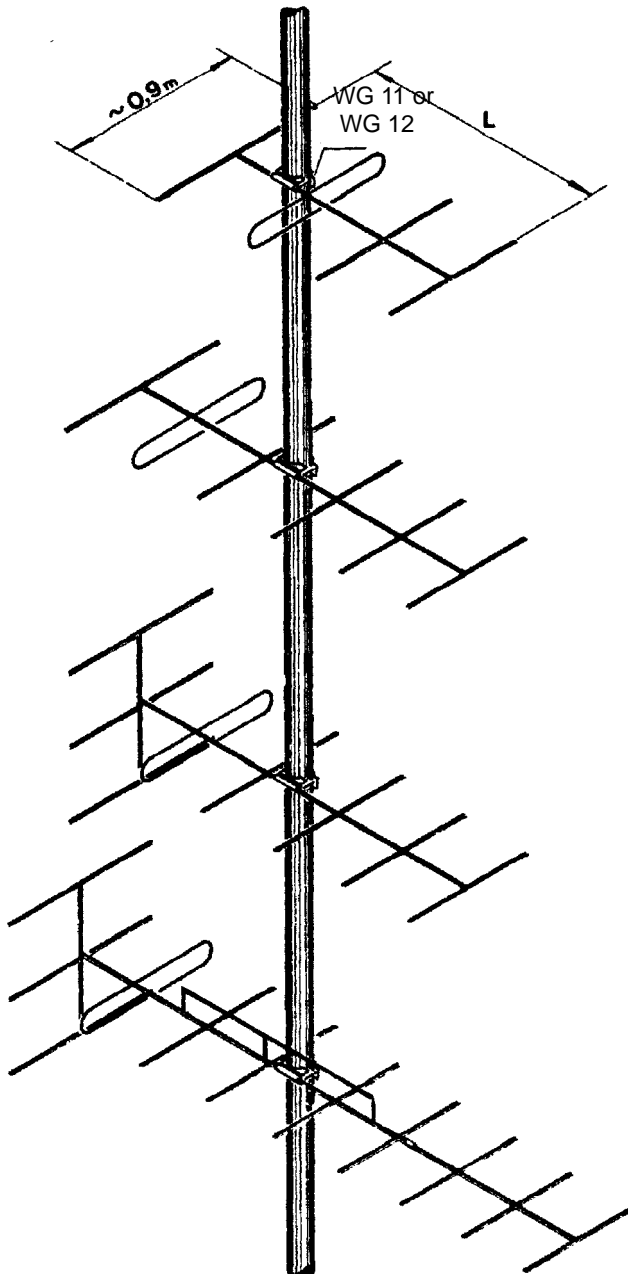

4-ELEMENT YAGI ANTENNA

type no. **FBE 304-0**
FBE 304-1
FBE 304-2

gain 5-7 dB ref. $\lambda/2$ dipole
F/B 18 dB

3 dB beam width horizontal, E plane 58°
vertical, H plane 90°

6-ELEMENT YAGI ANTENNA

type no. **FBE 306-0**
FBE 306-1
FBE 306-2

gain 6-9 dB ref. $\lambda/2$ dipole
F/B 20 dB

3 dB beam width horizontal, E plane 50°
vertical, H plane 66°

8-ELEMENT YAGI ANTENNA

type no. **FBE 308-0**
FBE 308-1
FBE 308-2

gain 7-11 dB ref. $\lambda/2$ dipole
F/B 25 dB

3 dB beam width horizontal, E plane 42°
vertical, H plane 56°

11-ELEMENT YAGI ANTENNA

type no. **FBE 311-0**
FBE 311-1
FBE 311-2

gain 8-12 dB ref. $\lambda/2$ dipole
F/B 25 dB

3 dB beam width horizontal, E plane 32°
vertical, H plane 45°

Type	
FBE 3..-0	no longer available
FBE 3..-1	balun with cable (for increased lightning protection) termination: 10 m RG 59 (ø 6.5 mm), without connector impedance: 75 Ω
FBE 3..-2	as FBE ...-1, but termination with 10 m RG 11 (ø 10 mm)

	channel	weight ¹⁾ [kg]	wind area[m ²]	wind load ²⁾ [N]	length L [m]	gain dB ³⁾
FBE 304-.	5-6	1.4	0.044	25	1.1	6.5
	7-8	1.4	0.041	23	1.0	6.5
	9-10	1.4	0.038	22	0.9	6.5
	11-12	1.4	0.036	21	0.9	6.5
	5-12	1.4	0.038	22	0.9	5-7
FBE 306-.	5-6	1.8	0.060	34	2.1	8.5
	7-8	1.8	0.056	32	2.0	8.5
	9-10	1.8	0.052	30	1.9	8.5
	11-12	1.8	0.048	27	1.7	8.5
	5-12	1.8	0.052	30	1.9	6-9
FBE 308-.	5-6	2.3	0.080	45	2.1	10
	7-8	2.2	0.076	43	2.0	10
	9-10	2.2	0.068	39	1.9	10
	11-12	2.2	0.063	36	1.7	10
	5-12	2.2	0.068	38	1.9	7-11
FBE 311-.	5-6	3.4	0.130	73	3.6	12
	7-8	3.3	0.128	72	3.5	12
	9-10	3.2	0.117	67	3.2	12
	11-12	3.1	0.110	63	2.9	12
	5-12	3.2	0.120	67	3.0	8-12

1) **weight** with clamp, without cable

weight of the cable: ø 6.5 mm : 0.6 kg/10m
 ø 10 mm : 1.6 kg/10m

3) ref. λ/2 dipole

2) **windload:** at 100 km/h
 at 130 km/h: multiply windload at 100 km/h by 1.7
 at 150 km/h: multiply windload at 100 km/h by 2.25

mounting: with clamp WG 11 for mast-ø 30-80 mm (standard)
 with clamp WG 12 for mast-ø 50-104 mm (option)
 connection box below the boom
 pay attention to the label DOWN

TV ANTENNAS (174 - 230 MHz)
for a channel group in the band III
channel 512
type without radome

FWS 304 02
FWS 306 02
FWS 312 02

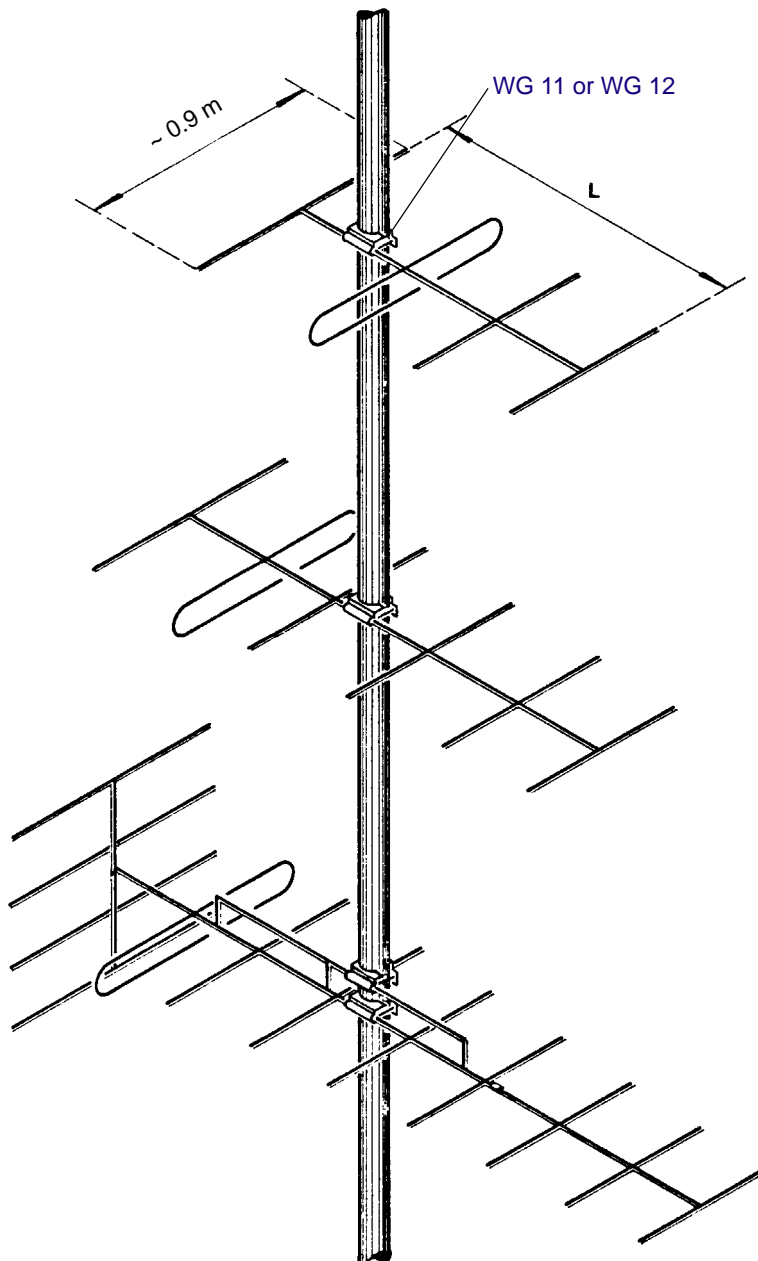

4-ELEMENT YAGI ANTENNA

type no. **FWS 304 02**
gain 5-7 dB ref. $\lambda/2$ dipole
F/B 18 dB

3 dB beam width horizontal, E plane 58°
vertical, H plane 90°

6-ELEMENT YAGI ANTENNA

type no. **FWS 306 02**
gain 6-9 dB ref. $\lambda/2$ dipole
F/B 20 dB

3 dB beam width horizontal, E plane 50°
vertical, H plane 66°

12-ELEMENT YAGI ANTENNA

type no. **FWS 312 02**
gain 8-12 dB ref. $\lambda/2$ dipole
F/B 25 dB

3 dB beam width horizontal, E plane 32°
vertical, H plane 45°

Description	robust construction VSWR individually measured especially suited for MATV For exposed locations (icing, environment, lightning) we recommend the type with radom (FWS 3.. 03)
Polarization	horizontal
Frequency	tuned to specified channel group, or for the band III
Impedance	50 Ω or 75 Ω
VSWR	< 1.3 on desired channel group < 1.5 for the whole band III
Termination	50 Ω: 2m cable RG 213/U ending with N male 75 Ω: 2m cable RG 11/U ending with N male
Material	aluminium, screws of stainless steel, weather-proof plastics
Grounding	all metal parts are DC grounded
Mounting	<i>mast-∅</i> <i>clamp</i> 30 - 80 mm WG 11 (standard) 2x for FWS 312 .. 50 -104 mm WG 12 (option) 2x for FWS 312 .. mast-∅ > 104 mm special order pay attention to the label DOWN
Max. wind velocity	180 km/h

	channel group CCIR	weight [kg]	wind area [m ²]	wind load [N]		length L [m]	gain ¹⁾ [dB]
				150 km/h	130 km/h		
FWS 304 02	5-6	1.7	0.044	56	42	1.1	6.5
	7-8	1.7	0.041	52	39	1.0	6.5
	9-10	1.6	0.038	48	36	0.9	6.5
	11-12	1.6	0.036	45	34	0.9	6.5
	5-12	1.6	0.038	48	36	0.9	5-7
FWS 306 02	5-6	2.1	0.060	76	57	2.1	8.5
	7-8	2.1	0.056	71	53	2.0	8.5
	9-10	2.0	0.052	66	49	1.9	8.5
	11-12	2.0	0.048	61	46	1.7	8.5
	5-12	2.0	0.052	66	49	1.9	6-9
FWS 312 02	5-6	3.8	0.080	102	76	3.6	12
	7-8	3.7	0.076	97	72	3.5	12
	9-10	3.6	0.068	86	65	3.2	12
	11-12	3.5	0.063	80	60	1.7	12
	5-12	3.6	0.068	86	65	3.0	8-12

¹⁾ ref. λ/2 dipole

Prices in SFr, gross, ex work

FWS 304 02	620.00
FWS 306 02	687.00
kw FWS 312 02	897.00

WIPIC reserves the right to amend specifications in the light of continuing development.

TV ANTENNAS (175-230 MHz)
for a channel group in the band III
channel 512
type with radome

FWS 304 03
FWS 306 03
FWS 312 03

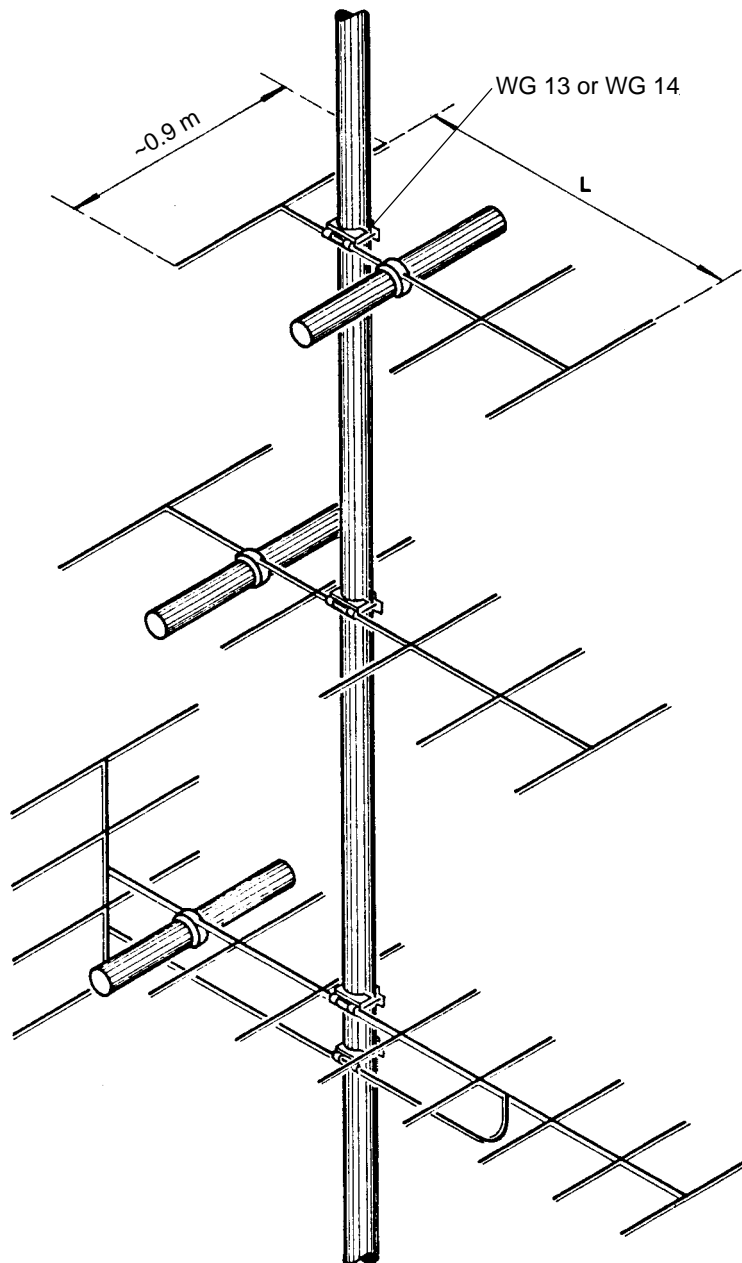

4-ELEMENT YAGI ANTENNA

type no. **FWS 304 03**
gain 5-7 dB ref. $\lambda/2$ dipole
F/B 18 dB

3 dB beam width horizontal, E plane 58°
vertical, H plane 90°

6-ELEMENT YAGI ANTENNA

type no. **FWS 306 03**
gain 6-9 dB ref. $\lambda/2$ dipole
F/B 20 dB

3 dB beam width horizontal, E plane 50°
vertical, H plane 66°

12-ELEMENT YAGI ANTENNA

type no. **FWS 312 03**
gain 8-12 dB ref. $\lambda/2$ dipole
F/B 25 dB

3 dB beam width horizontal, E plane 32°
vertical, H plane 45°

Description	heavy duty, with radome The radome protects the antenna dipole from environmental influences, icing, and increases the lightning protection. SWR individually measured especially suited for MATV										
Polarization	horizontal										
Frequency	tuned to specified channel group, or for the band III										
Impedance	50 Ω or 75 Ω										
VSWR	< 1.3 on desired channel group < 1.5 for the whole band III										
Termination	50Ω: 2m cable RG 213/U ending with N male 75Ω: 2m cable RG 11/U ending with N male										
Material	aluminium, screws of stainless steel, radome of uv-stabilized polyethylene										
Grounding	all metal parts are DC grounded										
Mounting	<table border="0"> <tr> <td><i>mast-ø</i></td> <td><i>clamp</i></td> </tr> <tr> <td>30 - 80 mm</td> <td>WG 13 (standard) 2x for FWS 312 ..</td> </tr> <tr> <td>50 -104 mm</td> <td>WG 14 (option) 2x for FWS 312 ..</td> </tr> <tr> <td>mast-ø > 104 mm</td> <td>special order</td> </tr> <tr> <td>pay attention to the label</td> <td>DOWN</td> </tr> </table>	<i>mast-ø</i>	<i>clamp</i>	30 - 80 mm	WG 13 (standard) 2x for FWS 312 ..	50 -104 mm	WG 14 (option) 2x for FWS 312 ..	mast-ø > 104 mm	special order	pay attention to the label	DOWN
<i>mast-ø</i>	<i>clamp</i>										
30 - 80 mm	WG 13 (standard) 2x for FWS 312 ..										
50 -104 mm	WG 14 (option) 2x for FWS 312 ..										
mast-ø > 104 mm	special order										
pay attention to the label	DOWN										
max. wind velocity	200 km/h										

	channel group CCIR	weight [kg]	wind area [m ²]	wind load		length L [m]	gain ¹⁾ [dB]
				150 km/h	130 km/h		
FWS 304 03	5-6	4.1	0.088	112	84	1.1	6.5
	7-8	4.0	0.082	104	78	1.0	6.5
	9-10	3.9	0.077	98	70	0.9	6.5
	11-12	3.8	0.073	93	70	0.9	6.5
	5-12	3.9	0.077	98	70	0.9	5-7
FWS 306 03	5-6	5.0	0.110	140	105	2.1	8.5
	7-8	4.9	0.103	131	98	2.0	8.5
	9-10	4.8	0.097	123	93	1.9	8.5
	11-12	4.6	0.091	116	87	1.7	8.5
	5-12	4.8	0.096	122	92	1.9	6-9
FWS 312 03	5-6	8.8	0.203	259	194	3.6	12
	7-8	8.5	0.188	240	180	3.5	12
	9-10	8.2	0.176	224	168	3.2	12
	11-12	7.8	0.166	212	159	2.9	12
	5-12	8.2	0.175	223	167	3.0	8-12

¹⁾ ref. λ/2 dipole

TV-ANTENNAS BAND IV/V

For a channel group in the band IV/ V (471 - 862 MHz)
channel 21 ... 69
horizontal polarization

FBE 406 -.

FBE 412 -.

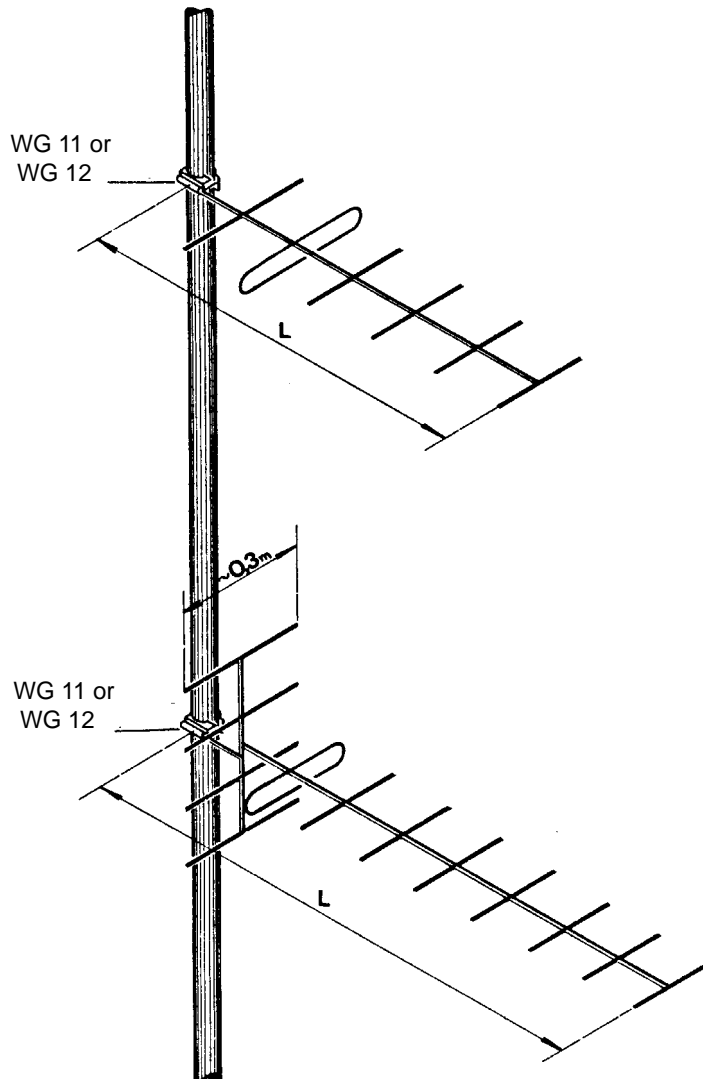

6-ELEMENT YAGI ANTENNA

type no. FBE 406-0
FBE 406-1
FBE 406-2

gain 8 dB ref. $\lambda/2$ dipole

F/B 20 dB

3 dB beam width horizontal, E plane 50°
vertical, H plane 66°

12-ELEMENT YAGI ANTENNA

type no. FBE 412-0
FBE 412-1
FBE 412-2

gain 11.5 dB ref. $\lambda/2$ dipole

F/B 25 dB

3 dB beam width horizontal, E plane 35°
vertical, H plane 50°

Type
FBE 4..-0 no longer available

FBE 4..-1 balun with cable (for increased lightning protection)
 termination: 10 m RG 59 (ø 6.5 mm), without connector
 impedance: 75 Ω

FBE 4..-2 as FBE ...-1, but termination with 10 m RG 11 (ø 10 mm)

	channel ³⁾	weight ¹⁾ [kg]	wind area [m ²]	wind load ²⁾ [N]	length L [m]
FBE 406-.	21-30	1.1	0.021	12	0.9
	31-41	1.1	0.019	11	0.7
	42-54	1.0	0.017	10	0.7
	54-69	1.0	0.015	9	0.6
FBE 412-.	21-30	1.7	0.039	23	1.3
	31-41	1.6	0.035	21	1.1
	42-54	1.5	0.032	19	1.0
	54-69	1.4	0.028	17	0.9

1) **weight** with clamp, without cable
 weight of the cable: ø 6.5 mm : 0.6 kg/10m
 ø 10 mm : 1.6 kg/10m

2) **windload:** at 100 km/h
 at 130 km/h: multiply windload at 100 km by 1.7
 at 150 km/h: multiply windload at 100 km by 2.25

3) **other channel** groups on request

mounting: with clamp WG 11 for mast-ø 30-80 mm (standard)
 with clamp WG 12 for mast-ø 50-104 mm (option)
 connection box below the boom
 pay attention to the label DOWN

TV-ANTENNAS BAND IV/V

For a channel group in the band IV/ V (470 - 862 MHz)
channel 21 ... 69
horizontal polarization

FBE 421 -.
FBE 431 -.
FBE 480 -.

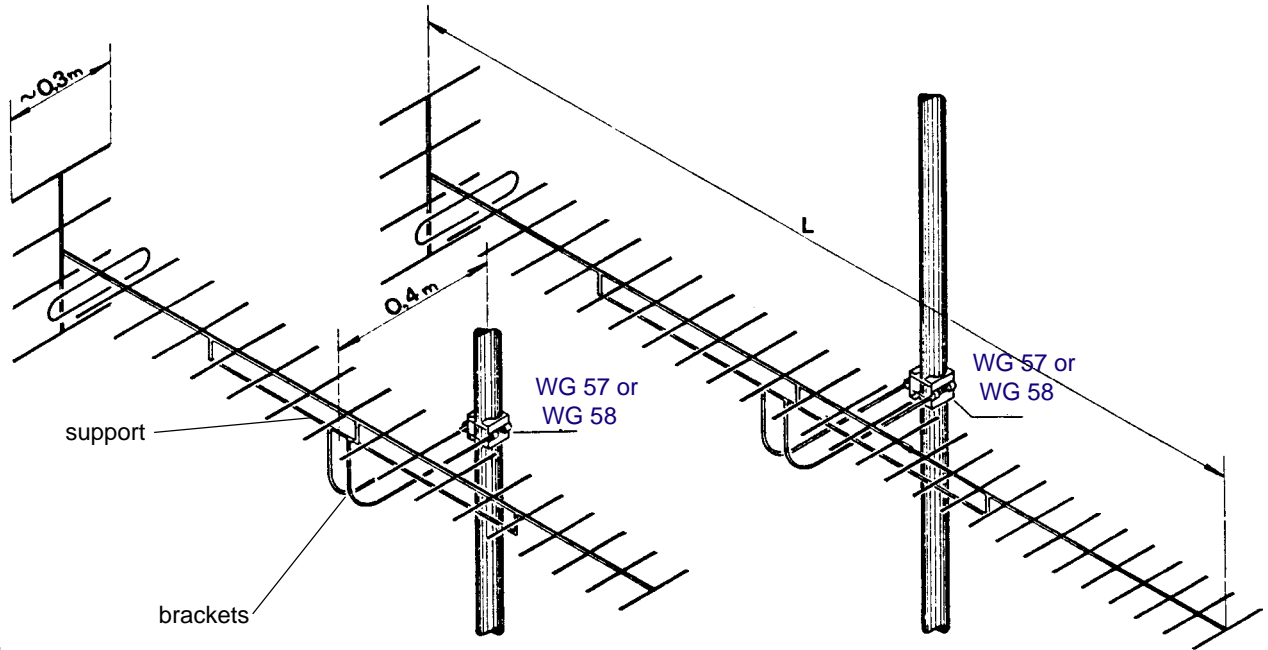

21-ELEMENT YAGI ANTIENNA

type no. FBE 421-0
FBE 421-1
FBE 421-2
gain 14 dB ref. $\lambda/2$ dipole
F/B 25 dB

3 dB beam horizontal, E plane 25°
width vertical, H plane 30°

For channel 21 to 36: delivery with WG 57 or WG 58
and support
For channel 37 to 69: delivery with WG 65 or WG 66
and support

31-ELEMENT YAGI ANTIENNA

type no. FBE 431-0
FBE 431-1
FBE 431-2
gain 16 dB ref. $\lambda/2$ dipole
F/B 25 dB

3 dB beam horizontal, E plane 20°
width vertical, H plane 24°

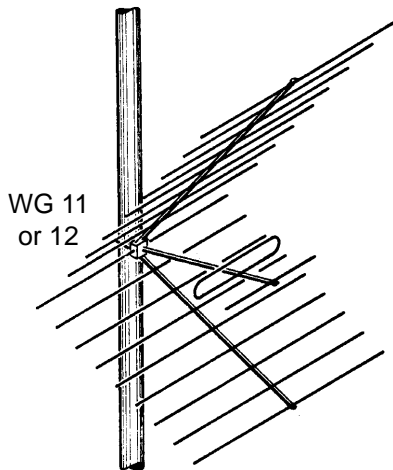

CORNERREFLECTOR ANTENNA CH. 21 - 69

type no. FBE 480-0
FBE 480-1
FBE 480-2
gain 8 - 11 dB ref. $\lambda/2$ dipole
F/B 18 - 25 dB

3 dB beam horizontal, E plane 55 - 45°
width vertical, H plane 48 - 40°

KW 9-01

WIPIC reserves the right to amend specifications in the light of continuing development.

Type	Description
FBE 4..-0	no longer available
FBE 4..-1	balun with cable (for increased lightning protection) termination: 10 m RG 59 (ø 6.5 mm), without connector impedance: 75 Ω
FBE 4..-2	as FBE ...-1, but termination with 10 m RG 11 (ø 10 mm)

	channel ³⁾	weight ¹⁾ [kg]	wind area [m ²]	wind load ²⁾ [N]	length L [m]
FBE 421-.	21-30	3.8	0.115	66	2.5
	31-41	3.6	0.105	60	2.2
	42-54	2.4	0.061	34	1.9
	54-69	2.2	0.050	28	1.5
FBE 431-.	21-30	4.8	0.161	91	4.1
	31-41	4.6	0.145	82	3.6
	42-54	4.3	0.123	70	3.0
	54-69	4.0	0.103	59	2.3
FBE 480 -.	21-69	3.4	0.11	62	0.5

1) **weight** with clamp, without cable
weight of the cable: ø 6.5 mm : 0.6 kg/10m
ø 10 mm : 1.6 kg/10m

2) **windload:** at 100 km/h
at 130 km/h: multiply windload at 100 km/h by 1.7
at 150 km/h: multiply windload at 100 km/h by 2.25

3) **other channel groups on request**

mounting: *FBE 421 .. and FBE 431 ..*
WG 57 30-80 mm (standard), respective **WG 65** for ch. 37-69
WG 58 50-104 mm (option); respective **WG 66** for ch. 37-69
FBE 480 ..
WG 13 30 - 80 mm (standard)
WG 14 50 - 104 mm (option)
other mounting on request
pay attention to the label **DOWN**

TV ANTENNAS

for a channel group in the band IV/ V (470 - 862 MHz)

channel 21 69

type without radome

FWS 412 02

FWS 421 02

FWS 431 02

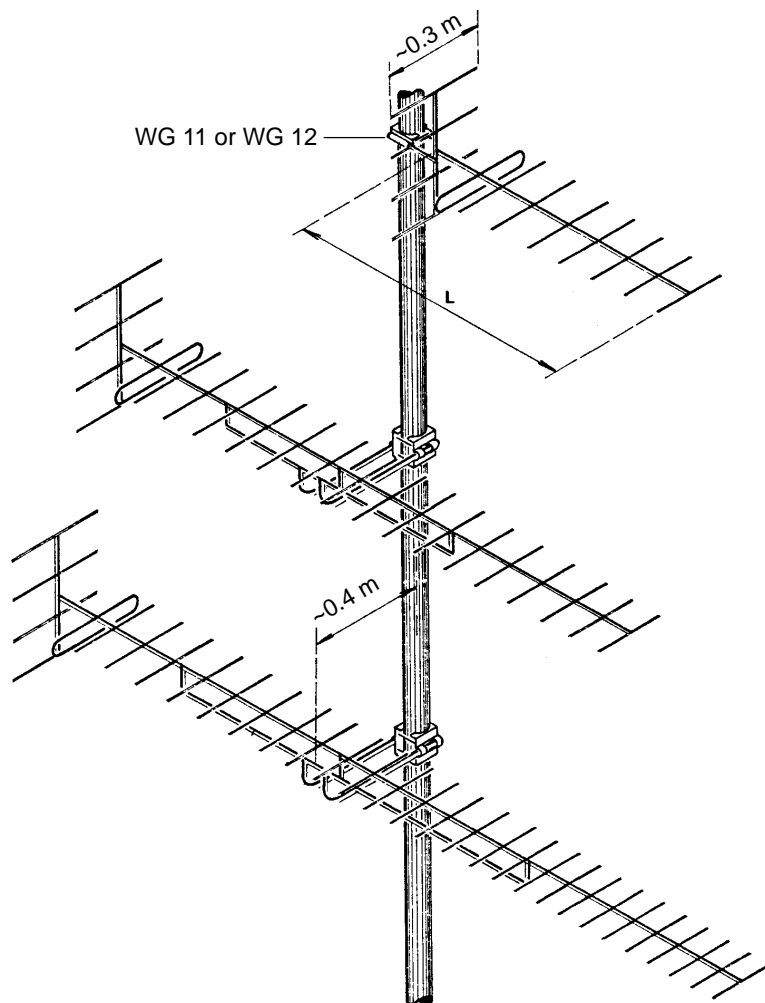

12-ELEMENT YAGI ANTENNA

type no. **FWS 412 02**

gain 12 dB ref. $\lambda/2$ dipole

F/B 25 dB

3 dB beam horizontal, E plane 35°

width vertical, H plane 50°

21-ELEMENT YAGI ANTENNA

type no. **FWS 421 02**

gain 14 dB ref. $\lambda/2$ dipole

F/B 25 dB

3 dB beam horizontal, E plane 25°

width vertical, H plane 30°

31-ELEMENT YAGI ANTENNA

type no. **FWS 431 02**

gain 16 dB ref. $\lambda/2$ dipole

F/B 25 dB

3 dB beam horizontal, E plane 20°

width vertical, H plane 24°

Description	robust construction VSWR individually measured especially designed for collective antenna systems for exposed locations (icing, environment, lightning) we recommend the type with radome (FWS 4.. 03)				
Polarization	horizontal				
Frequency	tuned to specified channel group				
Impedance	50 Ω or 75 Ω				
VSWR	< 1.5 on desired channel group				
Termination	50Ω: 2m cable RG 213/U ending with N male 75Ω: 2m cable RG 11/U ending with N male				
Material	aluminium, screws of stainless steel, weather-proof plastics				
Grounding	all metal parts are DC grounded				
Mounting clamps	<i>mast-ø</i>	<i>FWS 412</i>	<i>FWS 421 ch.21-36</i>	<i>FWS 421 ch. 37-69</i>	<i>FWS 431</i>
	30-80 mm	WG 11(stand.)	WG 57 (standard)	WG 65 (standard)	WG 57 (stand.)
	50 -104 mm	WG 12 (option)	WG 58 (option)	WG 66 (option)	WG 58 (option)
	mast-ø >104 mm	special order			
	pay attention to the label				DOWN
Max. wind velocity	180 km/h				

	channel group CCIR	weight [kg]	wind area [m ²]	wind load [N]		length L [m]
				150 km/h	130 km/h	
FWS 412 02	21-29	2.0	0.040	51	38	1.3
	30-41	1.9	0.036	45	34	1.2
	42-54	1.8	0.033	42	31	1.0
	55-69	1.7	0.029	37	27	0.9
FWS 421 02	21-29	4.2	0.119	152	114	2.6
	30-41	4.0	0.108	137	103	2.3
	42-54	3.2	0.067	85	64	2.1
	55-69	3.1	0.061	77	58	1.6
FWS 431 02	21-29	5.2	0.185	236	177	4.3
	30-41	5.0	0.158	201	151	3.8
	42-54	4.8	0.136	173	130	3.4
	55-69	4.5	0.119	152	114	2.6

TV ANTENNAS

for a channel group in the band IV/ V (470 - 862 MHz)
channel 21 69
type with radome

FWS 412 03

FWS 421 03

FWS 431 03

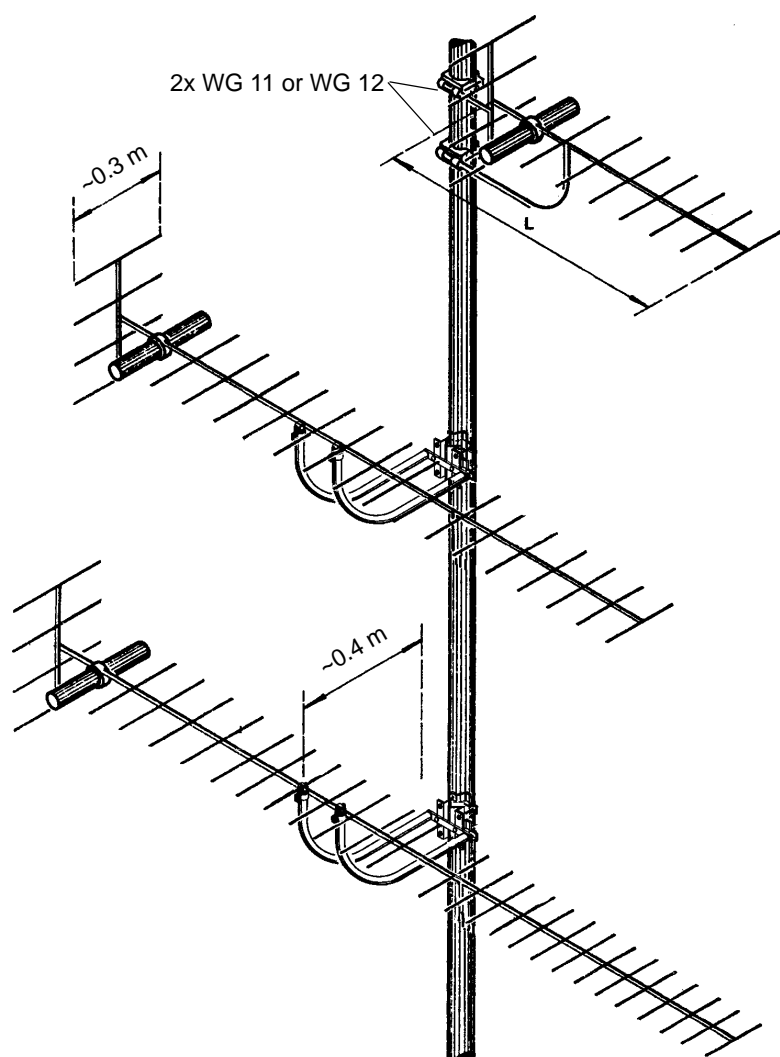

12-ELEMENT YAGI ANTENNA

type no. **FWS 412 03**
gain 12 dB ref. $\lambda/2$ dipole
F/B 25 dB

3 dB beam width horizontal, E plane 35°
vertical, H plane 50°

21-ELEMENT YAGI ANTENNA

type no. **FWS 421 03**
gain 14 dB ref. $\lambda/2$ dipole
F/B 25 dB

3 dB beam width horizontal, E plane 25°
vertical, H plane 30°

31-ELEMENT YAGI ANTENNA

type no. **FWS 431 03**
gain 16 dB ref. $\lambda/2$ dipole
F/B 25 dB

3 dB beam width horizontal, E plane 20°
vertical, H plane 24°

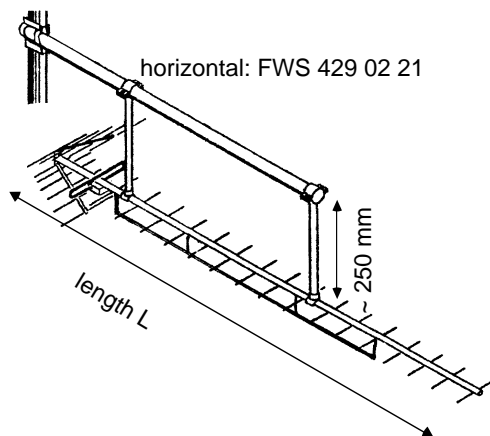

vertical: FWS 429 02 11 (by turning the antenna around the bracket)

TYPE	FWS 429 02 11 channel (vertical pol.) FWS 429 02 21 channel (horizontal pol.)	
IMPEDANCE	50 Ω or 75 Ω	
GAIN	15 dB (ref. λ/2 Dipol) F/B > 25 dB	
VSWR	< 1.5 on channel group	
MAX. POWER	150 watts	
3 dB BEAM WIDTH	in polarization, E-plane	23°
	rectangular to polarization, H-plane	27°
TERMINATION	50 Ω 2 m cable RG 213/U ending with N-male 75 Ω 2 m cable RG 11 ending with N male other termination on request	
GROUNDING	all metal parts are DC grounded	
MOUNTING	<i>mast-ø</i>	<i>clamp</i>
	30 - 80 mm	WG 17 (standard)
	50 - 104 mm	WG 18 (option)
	other clamps on request	
MATERIAL	aluminium, screws of stainless steel, weather-proof plastics	

channel CCIR	weight kg	length L mm	windarea m ²	wind load (N)	
				130	150 km/h
21 - 29	6.5	2300	0.15	143	192
30 - 41	6.1	2100	0.148	141	189
42 - 54	5.7	1900	0.146	140	186
55 - 69	5.4	1700	0.144	138	182

other channel group on request

PRICE 1171.00 SFr, gross, ex work

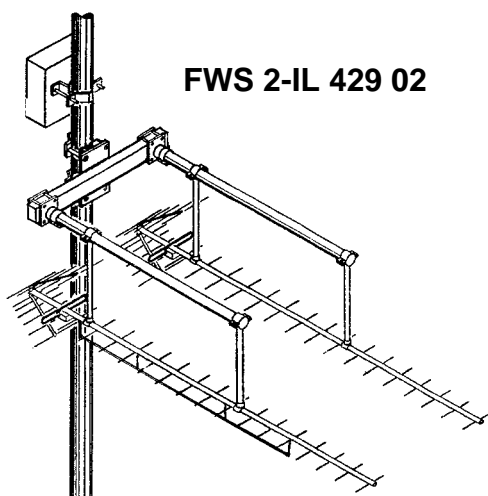

DESCRIPTION	coupling of two antennas increases the antenna gain variation of the distance produces zero roots at desired angles (see also: FWS 4 IL-429 02)
POLARIZATION	horizontal
GAIN	~18 dB
3 dB BEAM WIDTH	horizontal, E plane 16° vertical, H plane 26°
WEIGHT and WINDLOAD	add the datas of the two single antennas plus weight or windload of bracket and the junction box WAK 1: W=15 kg, A=0.15 m ² , WL=143/190 N
PRICE	3716.00 SFr , gross, ex work

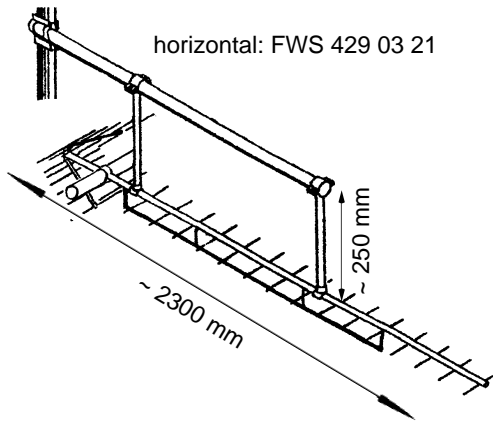

vertical: FWS 429 02 11 (by turning the antenna around the bracket)

TYPE	FWS 429 03 11 channel (vertical) FWS 429 03 21 channel (horizontal)	
DESCRIPTION	heavy duty, with radome The radome protects the antenna dipole from environmental influences, icing, and increases the lightning protection.	
IMPEDANCE	50 Ω or 75 Ω	
GAIN	15 dB (ref. λ/2 Dipol) F/B > 25 dB	
VSWR	< 1.5 for all channels of the group	
MAX. POWER	150 watts	
3 dB BEAM WIDTH	in polarization, E-plane	23°
	rectangular to polarization, H-plane	27°
TERMINATION	50 Ω 2 m cable RG 213/U ending with N male 75 Ω 2 m cable RG 11 ending with N male other termination on request	
GROUNDING	all metal parts are DC grounded	
MOUNTING	<i>mast-ø</i>	<i>clamp</i>
	30 - 80 mm	WG 17 (standard)
	50 - 104 mm	WG 18 (option)
	other clamps on request	
MATERIAL	aluminium, screws of stainless steel, radome of UV-stabilized polyethylene	

channel CCIR	weight kg	length L mm	windarea m ²	wind load (N)	
				130	150 km/h
21 - 29	12	2300	0.2	191	255
30 - 41	11	2200	0.2	191	255

other channel groups on request

YAGI ANTENNA ARRAY

for a channel in the band IV/ V (470 - 862 MHz)
channel 21 - 69

FWS 4 IL-429 02

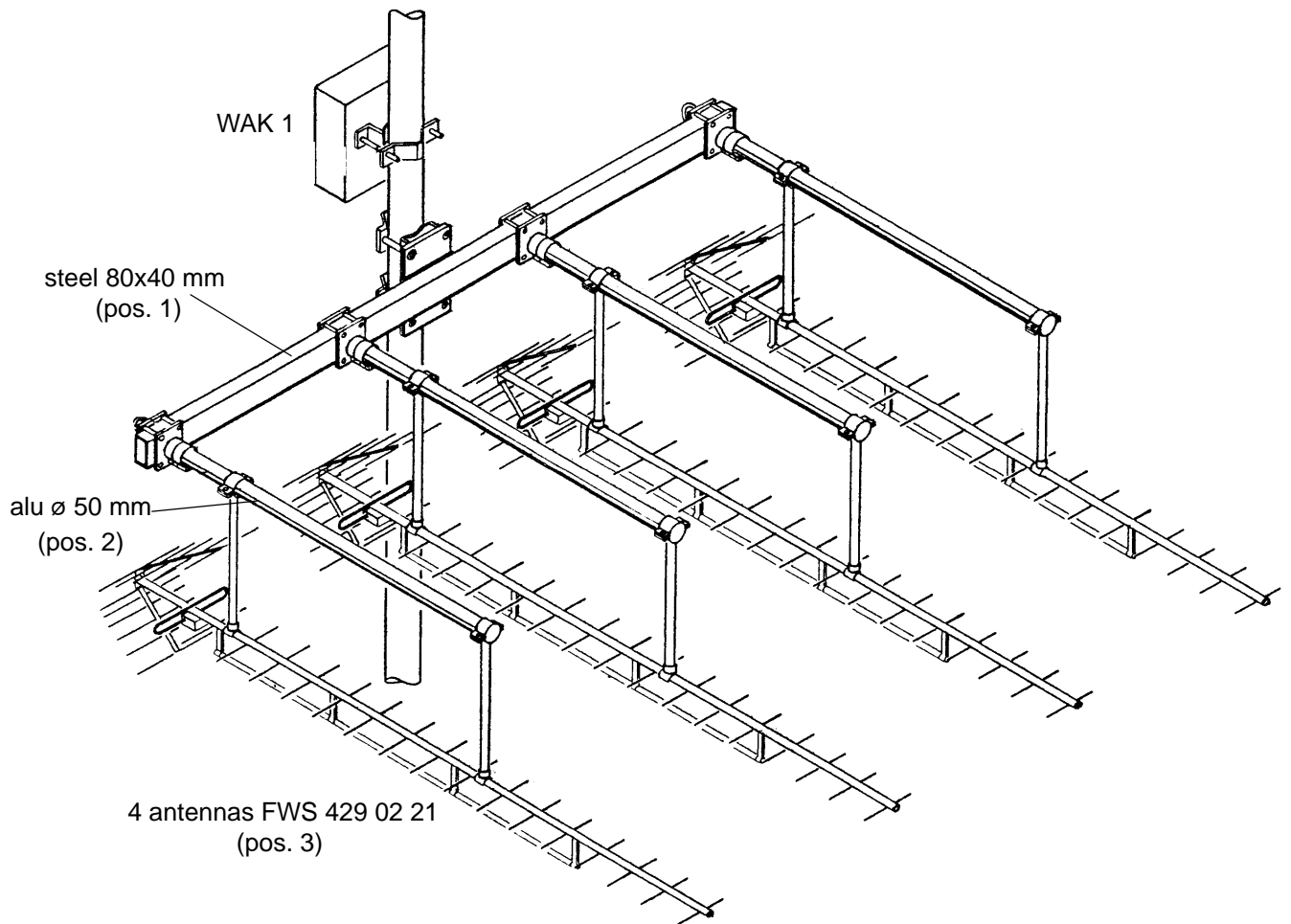

HORIZONTAL RADIATION PATTERN

ANGLE

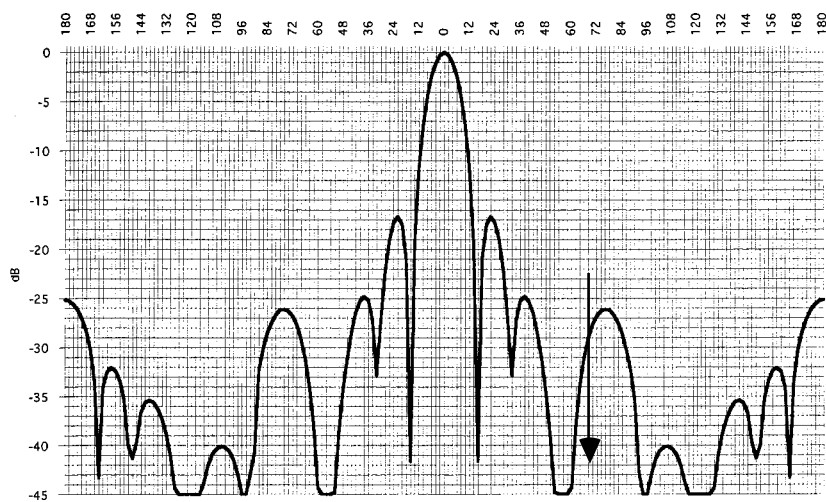

FWS 4 IL-429 02
zero root 52° (arrows)
distances 660-540-660



Description	variation of the distances between the antennas changes the angle of the zero roots which suppress undesired emitters	
Polarization	horizontal	
Frequency	tuned on a channel in the band IV/V (470 - 862 MHz) tuned on a channel group special order	
Impedance	50 Ω or 75 Ω	
VSWR	< 1.3 tuned to a channel < 1.5 tuned to a channel group	
3 dB beam width	horizontal, E-plane	9°
	vertical, H-plane	25°
Termination	50Ω: in the junction box WAK 1 ending with N male 75Ω: in the junction box WAK 1 ending with N male	
Material	aluminium, screws of stainless steel, hot dip galvanized steel	
Grounding	all metal parts are DC grounded	
Mounting	on mast with ø 50 - 104 mm mast-ø > 104 mm special order pay attention to the label DOWN	

	dimensions [m]			weight [kg]	wind area [m ²]	wind load [N]	
	pos. 1	pos. 2	pos. 3			150 km/h	130 km/h
channel 21	2.9	1.6	2.7	64	0.91	1162	873
channel 25	2.7	1.6	2.5	62	0.88	1124	844
channel 30	2.5	1.4	2.3	59	0.81	1034	777
channel 35	2.4	1.4	2.2	58	0.78	996	748
channel 40	2.2	1.3	2.0	52	0.62	791	594
channel 50	2.0	1.3	1.8	50	0.59	753	566
channel 60	1.8	1.1	1.6	47	0.54	690	518

FWSE

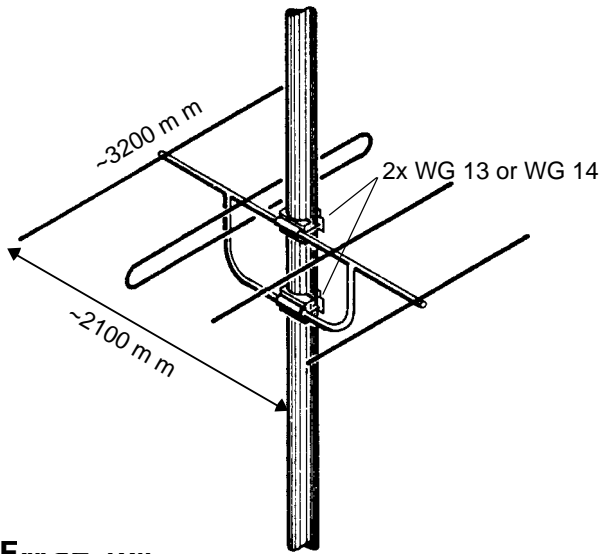

FWSE 104
for the Band I (47 - 68 MHz)
channel 2 - 4

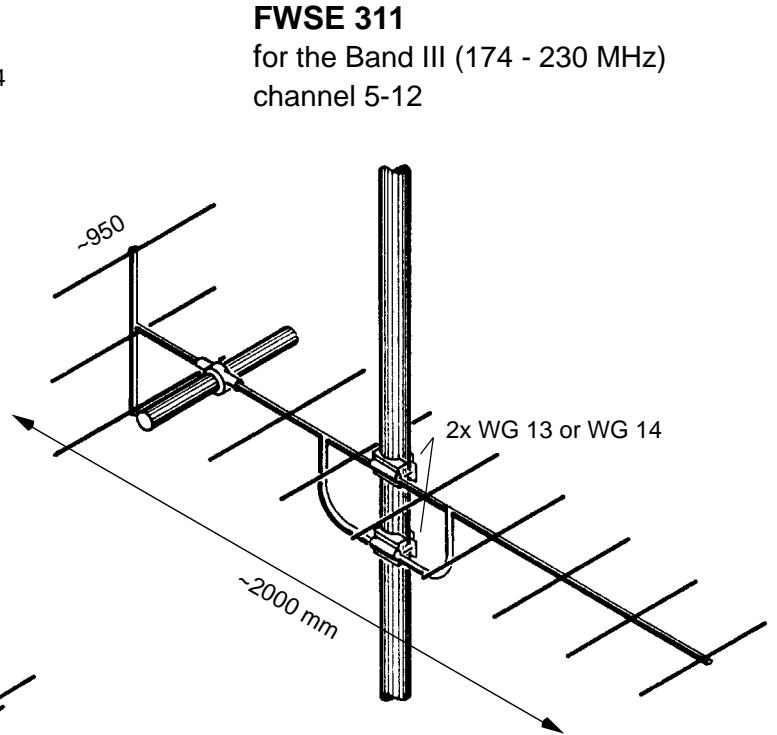

FWSE 311
for the Band III (174 - 230 MHz)
channel 5-12

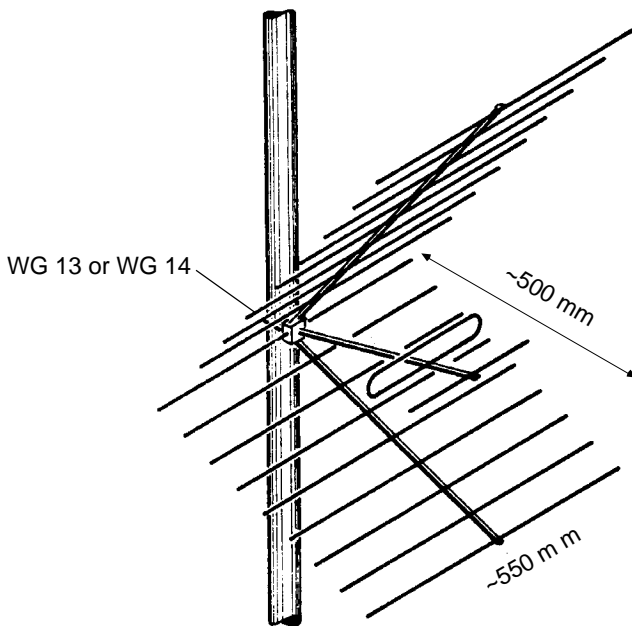

FWSE 480
for the Band IV / V (470 - 862 MHz)
channel 21 - 69

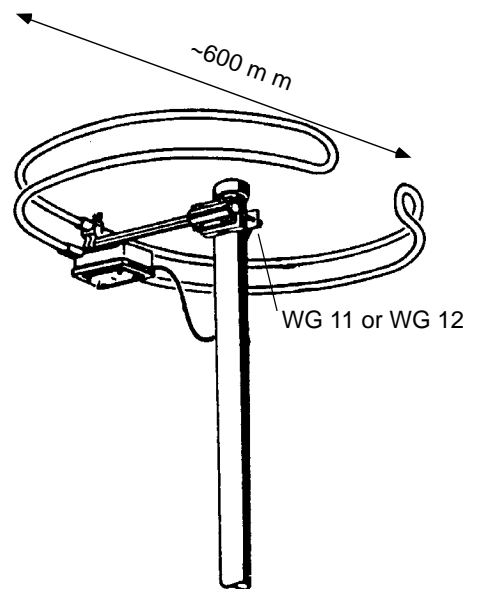

UBEE 200 -2
for the FM Band II (87.5 - 108 MHz)

DESCRIPTION	<p>specially rugged construction for ships seawater-proof aluminium alloy</p>
POLARIZATION	horizontal
IMPEDANCE	75 Ω
TERMINATION	<p>FWSE 104, FWSE 311, FWSE 480 and UBEE 200-2 : 10 m cable RG 11/U, without connector UBEE 200-2: with 10 m cable RG 11/U without connector</p>
MATERIAL	<p>20 μ anodized aluminium-anticorodal , screws of stainless steel, weather-proof plastics, radome of UV-stabilized polyethylene</p>
GROUNDING	all metal parts are DC grounded
MOUNTING	<p>mounting clamps: see illustrations pay attention to the label DOWN</p>

TYPE NO.	<i>FWSE 104</i>	<i>FWSE 311</i>	<i>FWSE 480</i>	<i>UBEE 200-2</i>
FREQUENCY [MHz]	47 - 68	174 - 235	470 - 860	87.5 - 108
GAIN (ref. to λ/2 dipole)	4 - 5	7 - 11	8 - 11	-2
F/B in dB >	10 - 15	17 - 25	18 - 25	
3 dB BEAMWIDTH				
horizontal, E plane	70 .. 65°	55 .. 40°	55 .. 45°	360°
vertical, H plane	105 .. 100°	60 .. 50°	48 .. 40°	
WEIGHT [kg]	11	9	5	1.5
WIND AREA [m²]	0.32	0.20	0.12	0.05
WIND LOAD [N]				
150 km/h	408	255	153	63
130 km/h	307	191	115	47